

DIESEL 1100cc MODEL **ZERO-TURN MOWER** **OWNER'S, SERVICE & PARTS MANUAL**

For additional information, please see us at
www.badboymowers.com

Bad Boy, Inc.
102 Industrial Drive
Batesville, Arkansas 72501



TABLE OF CONTENTS

Basic Information	Section 1	Page 4
Bad Boy Safety Guidelines.....	Section 2	Page 5
Operation	Section 3	Page 9
Maintenance.....	Section 4	Page 10
Storage and Transportation.....	Section 5	Page 10
Troubleshooting and FAQ	Section 6	Page 12
Controls.....	Section 7	Page 13
Moving In-operable Mower.....	Section 8	Page 14
Instrumentation	Section 9	Page 14
Mower Blade Maintenance.....	Section 10	Page 15
Greasing Bearings.....	Section 11	Page 15
How To Choose the Right Blade		Page 16
Mowing Tips.....		Page 17
Service Section		Page 18
Parts Section.....		Page 32
Limited Warranty		Page 52



THIS MANUAL APPLIES TO THE FOLLOWING EQUIPMENT:

BAD BOY DIESEL SERIES

Diesel Compact 6100 61" 1100CC 3-Cylinder Diesel

COMMONLY USED ITEMS AND PART NUMBERS

61" Blade	Hi-Lift Fusion 038-6080-00	Gator Blade 038-6081-00	Wave Blade 038-6090-00
Deck Belt	041-0236-00		
Pump Belt	041-5048-00		
Oil Filter	063-2010-00		
Air Filter	Inner Filter 063-2060-00	Outer Filter 063-2050-00	
Fuel Filter	063-2011		
Hydraulic Filter	063-8014-00		
Motor Oil	15W-40 Motor Oil – Reference Owner's Manual.		
Hydraulic Oil	20W-50 Motor Oil-Bad Boy Hydrostatic Oil Recommended (Approximately 2.5 Quarts/Transaxle) 085-6000-00		



SECTION 1: BASIC INFORMATION

Congratulations on the purchase of your new Bad Boy Mower! The purpose of this manual is to assist operators in maintaining and operating their machine. The information and instructions in this manual can help you attain years of performance from your new Bad Boy. Also, check out our website to learn more about the Bad Boy family.

- 1.1 All Bad Boy engines use 15W-40 engine oil. Refer to engine's service manual
- 1.2 All Bad Boy hydraulic systems use 20W-50 engine oil (Conventional or Synthetic). Bad Boy Hydrostatic oil is recommended.
- 1.3 All Bad Boy Mowers use hi-temp multi-purpose grease. NLGI No. 2 for the grease fittings.
- 1.4 1100CC Diesel models have 12 psi in both front and rear tires.
- 1.5 1100CC Diesel engines hold approximately three (3) quarts of motor oil. Be careful not to over fill engine oil. Refer to engine's service manual.

WARRANTY REGISTRATION

The Warranty Registration form must be completed within 30 days to validate your warranty. As the new equipment owner, you are expected to see that the form is completed and forwarded to Bad Boy Inc. at time of delivery. Warranty is nontransferable. **Warranty registration should be completed by the selling dealership using the on-line registration site.**

MODEL/SERIAL NUMBER

Your 1100CC Diesel model serial numbers are found on the SIN plate underneath the seat. These numbers can assist you in the ordering of new parts when replacements become necessary.

PARTS/SERVICE

Only Bad Boy replacement parts are to be used on your mower. Replacement parts are available through your local Bad Boy Mowers Dealer. Remember to always provide the following information when ordering parts:

1. Correct part number
2. Correct serial number

All warranty repair and service must be handled through your authorized Bad Boy Mowers Dealer. To locate the nearest dealer, go to our website and click on Locate a Dealer.



SECTION 2: MOWER SAFETY GUIDELINES

Never allow untrained people to operate this machine. It is the owner's responsibility to get training and see to it that anyone who has permission to use your machine receives the proper training. Do not mow around people. The factory discharge chute is designed to deflect debris downward, but it could be possible for debris to be thrown in a way that can cause damage to people or property. Seek additional training when possible to learn more about safety techniques and practices. **This cutting machine is capable of amputating hands and feet and throwing objects. Failure to observe the following safety instructions could result in serious injury or death.**

GENERAL OPERATION

- 2.1 Read, understand, and follow all instructions on the machine and in the manual before starting.
- 2.2 Do not put hands or feet near rotating parts or under the machine. Keep clear of the discharge opening at all times.
- 2.3 Always remain seated while operating the machine. If the machine is equipped with Roll Over Protection (ROPs), make sure ROPs are in the upright and locked position and always buckle your seat belt.
- 2.4 Only allow responsible adults who are familiar with the instructions to operate this machine.
- 2.5 Clear the area of objects such as rocks, wire, toys etc., which could be thrown by the blades
- 2.6 Always maintain a safe distance from people and pets just prior to, and during, operation. Stop the machine if anyone enters the area.
- 2.7 Never carry passengers.
- 2.8 Do not mow in reverse unless absolutely necessary. Always look down and behind before and while backing.
- 2.9 Never direct discharged material toward anyone. Avoid discharging material against a wall or obstruction as material may ricochet back toward the operator. Stop the blades when crossing gravel surfaces.
- 2.10 Never operate the machine without the discharge chute, grass catcher, or other safety devices correctly in place and functioning properly.
- 2.11 Slow down before turning.
- 2.12 Always disengage blades, place steering controls in neutral, engage parking brake, and remove ignition key when leaving operators seat. Never leave a running machine unattended.
- 2.13 Disengage blades when not mowing. Shut off engine and wait for all parts to come to a complete stop before cleaning the machine, inspecting the machine for damage, removing the grass catcher, or unclogging the discharge guard.
- 2.14 Always operate machine in daylight or with adequate working lights.
- 2.15 Do not operate the machine while under the influence of alcohol or drugs.
- 2.16 Watch for traffic when operating near or crossing roadways.
- 2.17 Always wear eye protection when operating or servicing the machine.
- 2.18 Always wear ear protection, such as earplugs, while mowing.
- 2.19 Use extra care when loading or unloading the machine into a trailer or truck.
- 2.20 Be alert of surroundings. Watch for rocks, stumps, mounds, depressions, and low hanging limbs or objects that could be potentially hazardous while mowing.
- 2.21 Data indicates that operators 60 years of age and above are involved in a large percentage of riding mower related injuries. These operators should periodically evaluate their ability to operate the riding mower safely enough to protect themselves and others from serious injury.



SLOPE OPERATION

Slopes are a major factor related to loss of control and tip over accidents, which can result in severe injury or death. Operation on all slopes requires extra caution. If you cannot back up the slope, or you feel uneasy on it, do not mow it.

- 2.22 Mow up and down slopes, not across.
- 2.23 Watch for holes, ruts, bumps, rocks, or other hidden objects that tall grass can obscure. Uneven terrain could overturn the machine.
- 2.24 Choose a low ground speed when operating the machine on a slope.
- 2.25 Do not mow on wet grass, the tires may lose traction.
- 2.26 Do not attempt to coast down a slope in the neutral position.
- 2.27 Avoid starting, stopping, or turning on a slope. If the tires lose traction, disengage the blades and proceed slowly, straight down the slope.
- 2.28 Keep all movement on slopes slow and gradual. Sudden changes in speed or direction could cause the machine to roll over.
- 2.29 Use extra care while operating machine with grass catchers or other attachments: they can affect the stability of the machine. Do not use on steep slopes.
- 2.30 Do not try to stabilize the machine by putting your foot on the ground.
- 2.31 Do not mow near drop offs, ditches or embankments. The machine could suddenly roll over if a wheel goes over the edge or the edge caves in.
- 2.32 Be aware of what is located at the bottom of slopes. For example: rocks, water, cliffs, and roadways.

CHILDREN

Tragic accidents can occur if the operator is not alert to the presence of children. Children are often attracted to the machine and the mowing activity. NEVER assume that children will remain where you last saw them.

- 2.33 Keep children out of the mowing area and in the watchful care of a responsible adult other than the operator.
- 2.34 Maintain Alertness and turn machine off if a child enters the area.
- 2.35 Before and while backing, look behind and down for small children.
- 2.36 Never carry children, even with blades shut off. They may fall off and be seriously injured or interfere with safe machine operation. Children who have been given rides in the past may suddenly appear in the mowing area for another ride and be run over or backed over by the machine.
- 2.37 Never allow children to operate the machine.
- 2.38 Never leave the key in the ignition, especially around children.
- 2.39 Use extreme care when approaching blind corners, shrubs, trees, or other objects that may block your view of a child



TOWING

1100CC Diesel:

Max pulling weight: 500lbs.

Max at 5°: 440lbs.

Max tongue weight: 110lbs.

- 2.40 Tow only with a machine that has a hitch specifically designed for towing. Do not attach towed equipment except at the hitch point.
- 2.41 Follow the manufacturer's recommendation for weight limits for towed equipment and towing on slopes.
- 2.42 Never allow children or others in or on towed equipment.
- 2.43 On slopes, the weight of the towed equipment may cause loss of traction and loss of control.
- 2.44 Travel slowly and allow extra distance to stop.

SERVICE

SAFE HANDLING OF DIESEL

To avoid personal injury or property damage, use extreme care in handling diesel.

- 2.45 Extinguish all cigarettes, cigars, pipes, and all other sources of ignition.
- 2.46 Use only an approved diesel container.
- 2.47 Never remove fuel cap or add fuel with the engine running.
- 2.48 Allow engine to cool before refueling.
- 2.49 Never fuel the machine indoors.
- 2.50 Do not store machine near open flame or source of ignition, such as a water heater or furnace.
- 2.51 Remove gas powered equipment from the truck or trailer and refuel it on the ground. If this is not possible, then refuel such equipment with a portable container, rather than from a gasoline dispenser nozzle.
- 2.52 Never fill diesel containers inside a vehicle or on a truck or trailer bed with a plastic liner. Always place containers on the ground away from your vehicle before filling.
- 2.53 Keep the nozzle in contact with the rim of the fuel tank or container opening at all times until the fueling is complete. Do not use a nozzle lock-open device.
- 2.54 If fuel is spilled on clothing, change clothing immediately.
- 2.55 Never overfill fuel tank. Replace gas cap and tighten securely. **Tank is full when level reaches bottom of fill tube.**

GENERAL SERVICE

- 2.56 Never operate machine in a closed area where dangerous carbon monoxide fumes can collect.
- 2.57 Keep all nuts and bolts tight to be sure the equipment is in safe working condition. Never operate a poorly maintained machine.
- 2.58 Do not touch hot areas of the machine.
- 2.59 Never interfere with the intended function of a safety device or reduce the protection provided by a safety device. Check their proper operation regularly.



- 2.60 Keep the entire machine free of grass, leaves, or other debris build up. Clean up oil or fuel spillage and remove any fuel soaked debris. Failure to do so can affect the safety and functionality of the machine, as well as increase the danger of a fire due to contact with the hot surfaces of the machine.
- 2.61 Allow machine to cool before storing.
- 2.62 If you strike something with the mower, turn the mower and blades off, engage the parking brake, and inspect the machine for damage. Repair, if necessary, before resuming.
- 2.63 Never make any adjustments or repairs with the engine running.
- 2.64 Check grass catcher components and the discharge guard frequently and replace with manufacturer's recommended parts, when necessary.
- 2.65 Mower blades are sharp. Wrap the blade or wear gloves before servicing them.
- 2.66 Check parking brake operation frequently. Adjust and service as required.
- 2.67 Maintain or replace safety and instruction labels, as necessary.
- 2.68 Do not attempt to mount a tire without the proper equipment and experience to perform the job.
- 2.69 Always maintain the correct tire pressure. Do not inflate the tires above the recommended pressure. Never weld or heat a wheel and tire assembly. The heat can cause an increase in air pressure resulting in a tire explosion. Welding can structurally weaken or deform the wheel.
- 2.70 Park machine on level ground. Never allow untrained personnel to service machine. Understand service procedure before doing work.
- 2.71 Mower deck, frame, and engine compartment should remain free of debris to prevent premature parts failures or fire hazards.

SAFETY INTERLOCK SYSTEM

Your Bad Boy mower is equipped with a safety interlock system. This system is designed to prevent serious injury or death to the operator and other people or property damage. The system consists of an operator presence switch in the seat, the parking brake, drive lever neutral position, the mower blade engagement switch, and the ignition switch. These interlocks are vitally important and must be tested frequently. Following are instructions to test these very important safety precautions. **Note: the operator must be seated properly on the machine during these tests and the engine should have been previously allowed to warm to operating temperature.**

- 2.72 With the parking brake engaged, bring lever arms to their inward position Attempt to start the machine with the blade actuator in off position. The engine should not start.
- 2.73 On a level surface, disengage the parking brake and place lever arms to their outward position. Then, attempt to start the machine with the blade actuator in off position. The engine should not start.
- 2.74 Engage parking brake and leave lever arms in outward position. Put blade actuator in the on position, then attempt to start the machine. The engine should not start.
- 2.75 Next, start the engine as stated in the Mower Operation Section. Disengage parking brake and, Very Slowly, begin to rise from the seat. The engine should stop.

If any of these tests fail to produce the results indicated and the problem cannot be identified, contact your Bad Boy Mower dealer or the support contacts in the rear of this manual.

ROLL OVER PROTECTION STRUCTURES (ROPS)

This machine is not equipped with ROPS from the factory. If ROPS are added as an option, it is vital that the rules below are adhered to. ROPS, when used correctly, dramatically decrease the fatality rate in roll-over instances.

- 2.76 Periodically ensure the bolts that attach the ROPS to the machine are securely fastened.
- 2.77 Always operate the machine with the ROPS secured in the upright position.
- 2.78 If the surrounding environment (e.g. low-lying limbs, signage, etc.) makes it impossible to mow with the ROPS upright, lower the ROPS at the hinge point, mow the area, then immediately secure the ROPS upright.
- 2.79 Upright ROPS are taller than then operators head. Be aware of this and your surrounding environment, as referenced above. The mower and operator may clear low lying items, but the ROPS may not.
- 2.80 Always wear the provided seat belt when ROPS are utilized. Failure to use the seat belt severely handicaps the safety benefits of the ROPS.
- 2.81 In the event of a roll-over, replace the ROPS before resuming use of the machine.



SECTION 3: MOWER OPERATION

Never operate the machine with faulty equipment. Always be alert of sudden changes in landscape, as the mower will react differently on slopes or embankments than it will on flat surfaces. Never operate the mower with the discharge chute open. Do not cross terrain, other than grass, with blades turning. This could cause damage to property or bystanders.

- 3.1 Place parking brake in up position.
- 3.2 Drive arms must be in the "open" position. While sitting on the machine, each arm is positioned away from the operator, to the right and left. Drive arms will lock into place and must be in this position to start machine.
- 3.3 Put PTO switch in the OFF position.
- 3.4 If your machine has been equipped with a ROPS (Roll Over Protection System) then you must fasten seatbelt.
- 3.5 If machine has not been started recently, engage the choke.
- 3.6 Make sure nothing is under or around machine.
- 3.7 Place key in ignition and turn.
- 3.8 Once machine is started, disengage the choke.
- 3.9 Increase RPM by sliding the throttle to fast position, toward the rabbit.
- 3.10 Owners must become familiar with the controls before operating a zero-turn radius vehicle.
- 3.11 Start slowly and build your skill level. Have ample practice before using the machine at full capabilities.
- 3.12 Be comfortable with machine before engaging blades. Know what each component controls before using machine.
- 3.13 Your mower will perform differently on an incline /decline. Be cautious, slow down, and do not make any sudden jerking movements with control arms. The machine could lose traction on a decline or tip backwards on an incline.
- 3.14 Once you become comfortable with your Bad Boy Mower you will notice your overall mowing time will decrease.

***Avoid operating your mower on side hills of over 5 degrees,
inclines of over 10 degrees,
and declines of over 15 degrees.***



SECTION 4: MOWER MAINTENANCE

Maintenance	Interval						Section
	Daily	Every 50 Hours or Annually*	First 75 hours	Every 100 Hours or Annually*	Every 250 Hours	Every 500 Hours	
Check and add engine oil	●						Section 3
Check all belts for proper alignment	●						Section 2 (Pump) 6 (Deck)
Check tire pressure and wheel lug nuts	●						Section 5
Check battery terminal connections	●						Section 4
Check condition of blades	●						Section 6
Check for fuel and oil leakage	●						Section 3
Check cooling system coolant	●						Section 3
Engine Air Cleaner inspection	●						Section 3
Fuel system primary filter/water separator inspection	●						Section 3
Initial change of hydraulic oil and filter		●					Section 1
Grease mower			●				Section 5
Tighten nuts and screws			●				Section 5
Fuel tank water and sediment drain				●			
Cooling system coolant sample ^{Dealer}					●		
Engine oil sample ^{**Dealer}					●		
Replace air element and pre-cleaner [♦]					●		Section 3
Change hydraulic oil and filter					●		Section 1
Change engine oil and filter					●		Section 3
Replace fuel filter [♦]					●		Section 3
Cooling system supplemental coolant additive-test/add ^{Dealer}						●	
Clean Radiator						●	Section 3

*Maintenance by hour or annually whichever comes first

**Maintenance by hour or every six months, whichever comes first

♦Check air and fuel filter more often in dusty conditions

^{Dealer}Get maintenance performed at a registered dealership

SECTION 5: MOWER STORAGE & TRANSPORTATION

- 5.1 Keep machine from collecting debris by storing in a covered area while not in use.
- 5.2 Fuel can harm your machine if left for more than 30 days without changing.
- 5.3 Disconnect the negative battery cable when machine will be stored for more than 30 days.
- 5.4 Always secure machine properly when transporting machine.
- 5.5 Do not load machine on trailer with blades engaged.
- 5.6 Do not use ramps to load the machine.
- 5.7 Make sure Parking Brake is in "up" position.
- 5.8 In wet conditions tires may spin while loading / unloading. If necessary, wait for dry conditions before loading/unloading.
- 5.9 Make sure mode of transportation is suitable to bear the weight of mower.
- 5.10 Deck height should be set at maximum before attempting to load.
- 5.11 Secure mower with at least two straps capable of securing weight of mower.



SECTION 6: TROUBLESHOOTING

6.1 **Q: *How do I prevent an uneven cutting pattern and increase the quality of cut?***

A: Check tire pressure, check blade sharpness (replace blades or sharpen at least once per year or when needed), make sure blades are tightened properly, check spring and belt tension, check the underside of the deck to ensure the mower deck is free of grass build-up and debris, make sure your machine is at full throttle, and vary your mowing pattern each time you cut your grass.

6.2 **Q: *What should I do if my mower won't start?***

A: Check battery charge and connection (grounds), check your fuel (make sure fuel is less than 30 days old and contains no water), make sure your spark plug is in good condition and spark plug wire is attached, and make sure air filter is clean (a dirty filter makes it more difficult for the engine to draw air). Check the integrity of the 25-amp main fuse; also check for any bare wires and/or bad connections.

6.3 **Q: *What should I do if the blades won't engage?***

A: Make sure the safety switch is plugged in on the bottom of seat. Check the underside of the PTO engager to ensure the plug is secure at switch. Also check PTO fuse underneath operator console (10-amps)

6.4 **Q: *What type of fuel is recommended for my mower?***

A: We recommend that you use a name brand fuel to ensure quality. Use fuel with an octane rating near 87. Higher octane fuels offer no benefit. Only fuels with an ethanol content of 10% or less may be used. By law, E-15 fuel is not permitted. Usage of E-15 will result in premature engine failure.

6.5 **Q: *Do you offer touch-up paint for your mowers?***

A: Touch-up paint is available. Contact your local dealer for more information.

6.6 **Q: *How do I clean my mower?***

A: It is recommended that you use an air hose or blower to remove dust and debris from the mower, to ensure there is not a buildup of grass on the mower deck and engine compartment, which could become a fire hazard. If you must wash the mower, ensure you run the engine to operating temp to dry water and engage the blades to spin off any standing water on the pulleys. Avoid spraying water onto electrical components and bearings, to prevent premature failure of these parts.

SECTION 7: CONTROLS

- 7.1 **Ignition Switch:** Bad Boy mowers have a three-position ignition switch: off, run, and start. With key inserted, rotate it clockwise to START position and release key when engine starts, and switch will automatically return to the RUN position.
- 7.2 **Throttle Control:** A cable is connected to the engine throttle for controlling engine speed. Move lever forward to increase engine rpm, move lever backward to decrease engine rpm.
- 7.3 **Pre-Heat Button:** Before starting engine push to pre-heat for easier starting.
- 7.4 **Control Levers:** These levers control the mower's speed, direction, and neutral lock. These levers are used to steer, accelerate, decelerate and change direction.
- 7.5 **Blade Engage Switch:** This switch engages the blades. Pull the switch up to engage the blades and push the switch down to disengage the blades.
- 7.6 **Deck Lift Control:** The deck lift switch is used to raise and lower the deck. Pull the switch backwards to raise the deck and push the witch forward to lower the deck.

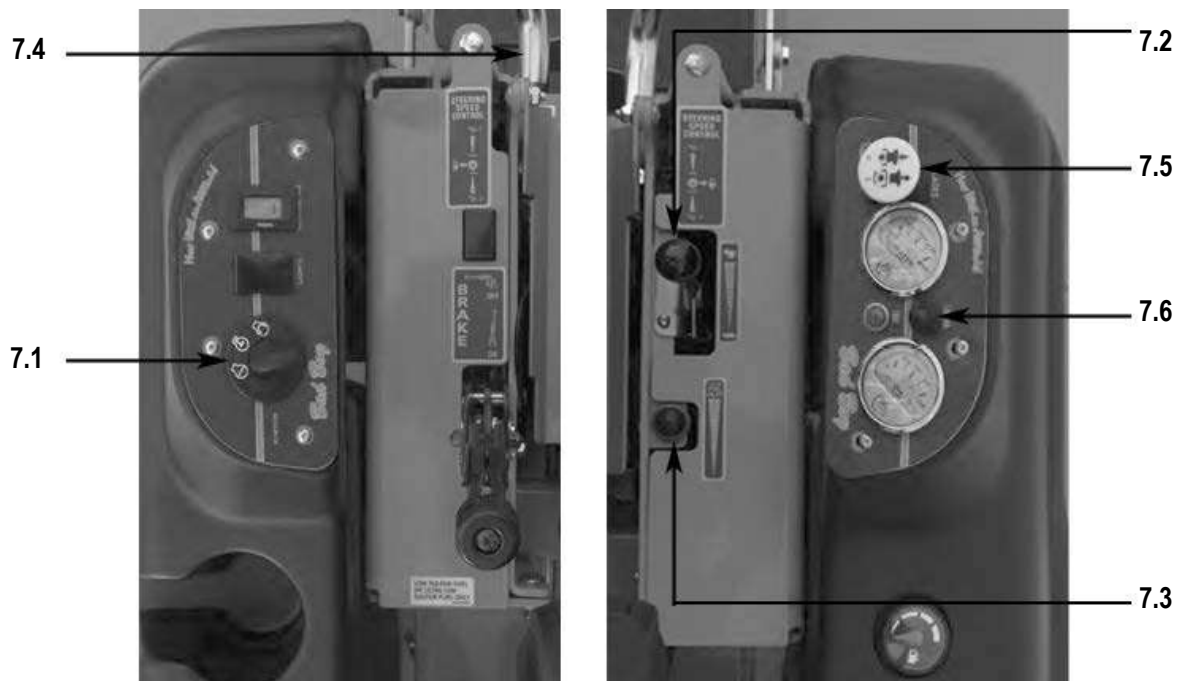



SECTION 8: MOVING INOPERABLE MOWER

- 8.1 Do not tow machine. Use a winch to load on a trailer for transporting.
- 8.2 **ATTENTION:** RETURN BYPASS VALVES TO OPERATING POSITION BEFORE RUNNING MOWER FOLLOWING REPAIRS.
- 8.3 If it is necessary to move mower when the engine is inoperable, the hydraulic drive pumps are equipped with bypass valves. Before moving the mower, turn the bypass valves counterclockwise one-half to one revolution. The bypass valve bolts are located on the side of each pump and are easily identified by the hole through the bolt heads

Your Bad Boy Mower Weighs: **DIESEL: 1607 lbs.**

****Weights fluctuate with the addition of accessories.*

- 8.4 As you can see by the weights of the machines, you shouldn't ever try to push or pull a Bad Boy Mower by hand. This could cause serious bodily injury.
- 8.5 Hopefully, you'll never need to use this section of the manual. However, if you do, use extreme caution when moving machine!

SECTION 9: INSTRUMENTATION

- 9.1 **Electronic Hour Meter:** Displays total operating hours (0.1 hour increments, up to 9,999.9 hours), resettable timers, oil change reminders (5 hour break-in reminder followed by 50 hour interval reminders), air filter cleaning reminder, and RPM gauge. Press button to cycle between functions. To reset a timer, depress and hold button for 2 seconds.
- 9.2 **Oil Light:** Alerts the operator that there is a low oil pressure situation inside the engine.
- 9.3 **Check Engine Light:** Alerts the operator that the ECM has detected an issue with the engine



SECTION 10: MOWER BLADE MAINTENANCE

- 10.1 Check mower blades after each use. This is essential for maintaining well-groomed turf. Keep the blades sharp. If a dull blade is used for cutting, the grass will tear rather than cut. This could damage the grass leaving a brown frayed top on the grass within a few hours. A dull blade will also require more power from the engine.
- 10.2 NEVER attempt to straighten a bent blade by heating. NEVER attempt to weld a cracked blade. The blades can break and cause serious injury or death.
- 10.3 NEVER work with blades while engine is running or deck clutch is engaged.
- 10.4 ALWAYS place deck clutch in DISENGAGE position while performing maintenance.
- 10.5 Use blocks when you MUST work under mower.
- 10.6 ALWAYS wear thick gloves when handling blades.
- 10.7 ALWAYS check for blade damage if mower strikes rock, branch, or other objects that could potentially damage the blade.

***(REMEMBER: NEVER CHECK BLADE WHILE ENGINE IS ON!
NEVER CHECK BLADES WHILE BLADES ARE ENGAGED!)***

SECTION 11: EQUIPMENT LUBRICATION

- 11.1 Park the machine on a level surface and disengage the blade control switch.
- 11.2 Move the motion control levers outward to the neutral position, engage parking brake, stop the engine, remove the key, and wait for all moving parts to stop before leaving the operating position.
- 11.3 Grease Type: NLGI grade #2 multi-purpose gun grease.
- 11.4 Clean the grease fittings with a cloth. Scrape any paint off the front of the fitting(s).
- 11.5 Connect a grease gun to each fitting. Pump grease into the fitting until grease seepage is observed. Be mindful of over-pressurization. Do not force the lever arm if there is strong back pressure as this can lead to reduced life of the component(s). Wipe up excess grease.
- 11.6 Refer to service manual section for grease fitting locations.



HOW TO CHOOSE THE RIGHT BLADE

Essentially there are only TWO basic styles of mowing blades used or approved for use on our current products:

1. The standard style of mowing blade is essentially designed for cutting grass and effectively discharging the clippings out from the deck to fall onto the lawn or to be captured in a grass collection system. Standard blades are also referred to as "2-in-1" (discharging & bagging) or "high-lift" blades (because they are designed to create a higher-lifting airflow).
2. Mulching blades generally have a more curved style surface and frequently include extra cutting surfaces along the blade edges. These blades may also come in a "+" design (which is actually two individual blades arranged in a perpendicular fashion to enhance mulching). The "+" blades are usually found on older style mowers; newer ones utilize blades with more advanced mulching technology. Mulching blades may also be referred to as "3-in-1" (mulching, discharging & bagging) or "all-purpose" blades.

Bear in mind that the re-circulating airflow design of 3/1 blades makes them less efficient at discharging grass clippings than a standard 2/1 blade. As with most all-purpose tools, there is some give and take as opposed to using a tool designed for a more specific purpose.

If you're experiencing less-than-desired cutting or discharging performance with a 3/1 blade, you may want to check into using a 2/1 blade. Conversely, if you're using a 2/1 blade and want to mulch clippings, you should see about the availability of mulching blades or a mulching kit. *

The type of blade installed on a new mower is a decision the retailer makes for each model of mower, based on the expected needs of most customers. If you're unsure of which blade is on a particular model, inspect the blade. Blades have part numbers stamped into them. Then compare these part numbers with the unit's Operator's Manual or Parts List.

It is true there are many other styles of blades available. But since we don't manufacture or recommend using these other aftermarket styles, we will leave them out of this discussion. Should you want more information on special application or aftermarket blades, you should contact the companies that make these products. NOTE: Customers using non-OEM blades do so at their own risk. The use of unapproved (non-OEM) blades may void any or all of the mower and engine factory warranties.

* **MULCHING KITS** – These generally consist of mulching blades and a mulching plug (which closes off the discharge opening to keep the clippings contained under the deck for re-cutting) plus any necessary hardware for installation. Please check with your parts distributor regarding the contents of a particular mulching kit.

MOWING TIPS:

- Mow header strips at the ends of the lawn and around flower beds first. Make them wide enough that you can turn the mower around in the already mown section. Then mow back and forth between these header strips overlapping each lap by about 1/8 the width of the mower's deck.
- Don't cut your grass too short, particular for cool season grasses. Higher heights usually provide for a deeper root system, looks better, and is less likely to have weeds invading, particularly crabgrass.
- Don't remove any more than one third of the grass leaf at any one cutting. If circumstances arise that a lawn gets too tall and you just have to lop off a bunch to get caught up, bite the bullet and break it down into several mowings to get caught up with 3 or so days between cuttings.
- NEVER SCALP YOUR LAWN.** Scalping severely damages the root system to such a degree that it may die.
- Avoid mowing when the grass is wet or when it's dark
- Avoid throwing grass clippings into the street and driveway where they can be washed into the sewer system. After mowing, clean up driveway and walkways.
- When mowing remove only a third of the height of the grass with each cutting (except for the first mowing of the season when it's ok to remove more). You can safely leave clippings that will quickly decompose and add nutrients back into the soil. Contrary to popular opinion, grass clippings do not add to thatch buildup. Grass blades are made up of about 75% water.
- Mow your lawn in a different direction with each mowing, especially with lawns of shorter grass types. Altering the direction ensures a more even cut since grass blades will grow more erect and less likely to develop into a set pattern.
- Keep your mower's blade sharp, which means having it sharpened several times during the mowing season. Keep several blades around so you'll always have a sharp one on hand. Sharp blades cut the grass cleanly and help mulch clippings into small pieces which break down quickly.
- Don't forget to change your mower's oil at least once during the mowing season. For brand new mowers, change the oil after about 5 hours of operation during the initial break-in period.
- At the end of the mowing season use a fuel stabilizer in the remaining gasoline
- In the spring, don't use that old gas unless you properly used a fuel stabilizer, it can cause a number of problems. Better to use fresh gasoline to begin the new mowing season.
- Leaf blade A** demonstrates what a leaf blade should look like after mowing with a sharp blade.
- Leaf blade B** demonstrates a leaf blade that was injured by a dull mower blade.
- Leaf blade C** was cut by the mower but indicates that the mower blade is not sharp enough. The shredded white tissue protruding from the leaf blades C and D is the vascular tissue of the plant.
- Leaf blade D** has been mown for quite some time with a dull mower blade.

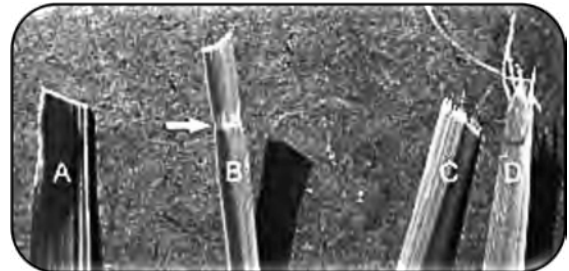

TO BAG OR TO MULCH?

Grass clippings do not contribute to thatch buildup or increase the chances of disease. If you mow your lawn at the right height, without removing any more than 1/3 of its total height, clippings will quickly breakdown without a trace. These clippings contribute additional nitrogen and other nutrients to the soil and supply it with additional organic materials. Clippings from a 1000 sq. ft. lawn can add as much as 1 - 2 pounds of nitrogen back into the soil. If you have a compost pile, then you may want to bag your clippings occasionally to add much needed green-matter to the compost pile. Make sure it is mixed thoroughly with brown matter to avoid a strong ammonia odor. **DO NOT COMPOST CLIPPINGS** after applying any weed control or weed-feed type product. Before adding clippings to the compost pile wait at least 3 mowings after these products have been applied.



SERVICE SECTION

SECTION 1: HYDROSTATIC SYSTEM

The hydraulic reservoir tank on the Diesel 1500cc model is located under the seat. There is a dipstick that indicates the current hydraulic oil level. Use only 20W-50 motor oil in this tank. Conventional or synthetic oil may be used. Bad Boy Hydrostatic Oil is recommended. Bad Boy recommends that the hydraulic oil and filters be changed within the first 50 hours of use; then at intervals of 250 usage hours. Use only Bad Boy replacement filters. Use of any other filters may result in damage to the hydraulic system and void the warranty. Each side requires approximately two quarts of oil to refill the system.

THE FOLLOWING MAINTENACE IS TO BE PERFORMED ON A LEVEL SURFACE.

CHANGING YOUR HYDRAULIC OIL AND FILTER

1. Place an oil drain pan under the engine plate and place the hydraulic return lines that go into the top of the hydraulic reservoir tank into the oil pan. Remove the cap from the hydraulic reservoir tank.
2. Start the engine in order to cycle out the old hydraulic oil.
3. When you see air bubbles in the hydraulic lines immediately shut off the mower. Keep in mind that only 75-80% of the hydraulic oil can be changed at a time.
4. Place rags under the hydraulic filters. Turn the hydraulic filters counter clockwise to remove.
5. Fill the new hydraulic oil filters with 20W-50 motor oil. Only use Bad Boy replacement filters.
6. Place the hydraulic return lines back onto the hydraulic reservoir tank. Fill the hydraulic reservoir tank until the oil level reaches the bubble on the dipstick. Be careful not to overfill the hydraulic reservoir tank.
- 7) Proceed to the purge procedure.

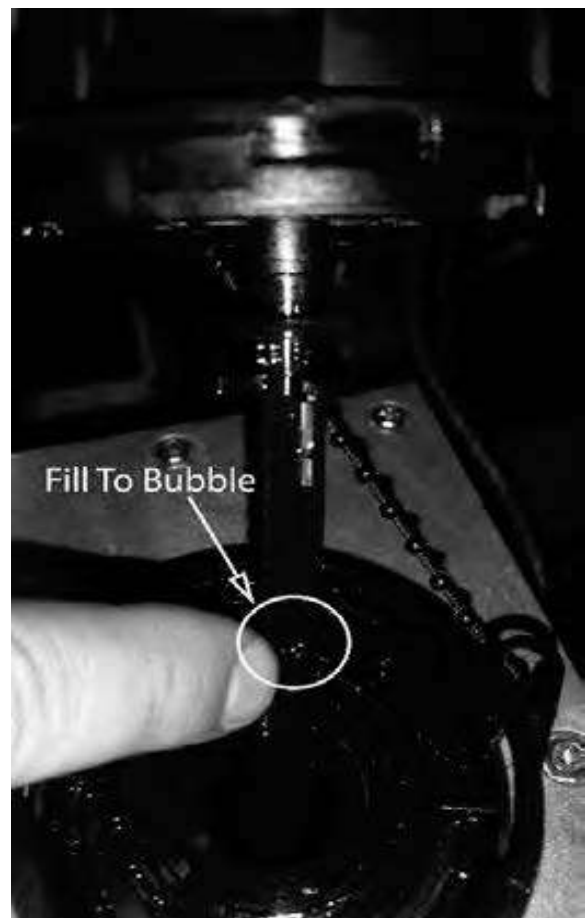
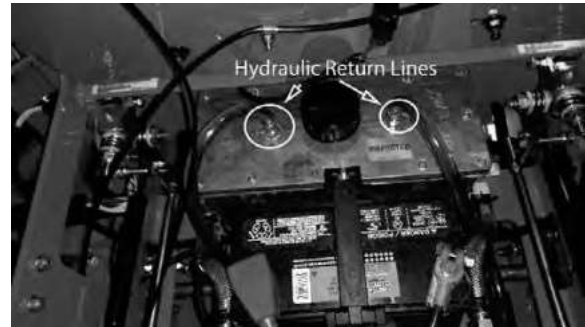

PURGING PROCEDURE

Due to the effects air has on the efficiency in hydrostatic drive applications, it is critical that the air is purged from the system. These purge procedures should be implemented any time a hydrostatic system has been opened to facilitate maintenance or any additional oil has been added to the system.

1. Lift the rear tires of the mower off of the ground and chock your front tires so they do no move.
2. With the bypass valve open and the engine running, slowly move the directional drive arms in the forward and reverse directions (5 to 6 times), as air is purged from the unit, the oil level will drop.
3. With the bypass valve closed and the engine running, slowly move the directional drive arms in the forward and reverse directions (5 to 6 times). Check the oil level, and add oil as required after stopping the engine.
4. It may be necessary to repeat steps 2 and 3 until all the air is completely purged from the system. When the transaxle moves forward and reverse at normal speed purging is complete.

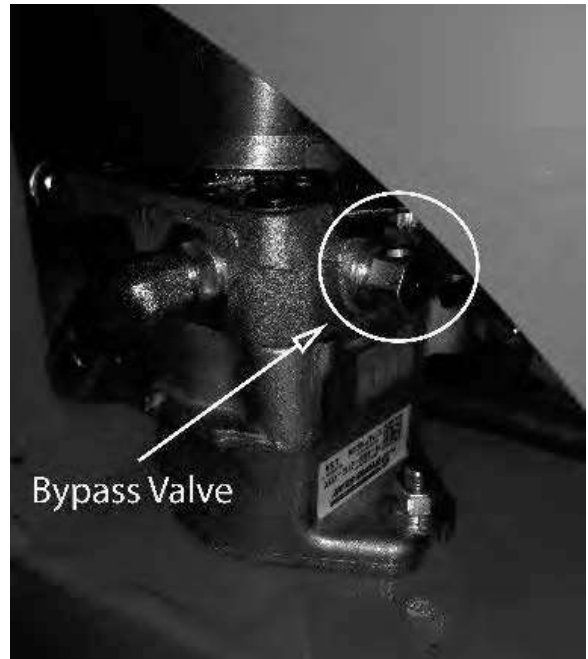



SECTION 2: DRIVE BELT

Shown on the right is the tensioner for your pump belt. Adjusting this will either increase or decrease tension on the belt. Use a 3/4" wrench to loosen the jam nuts and either tighten for more belt tension or loosen for less belt tension.

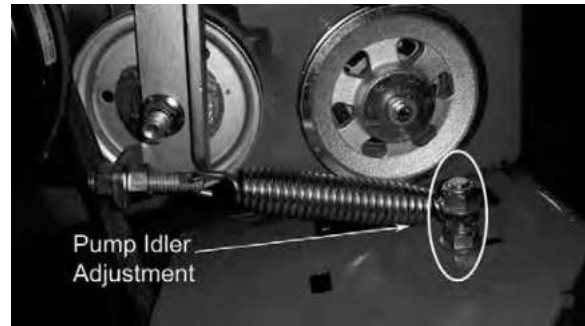

The belt tension should be set to 50-60 lbs.

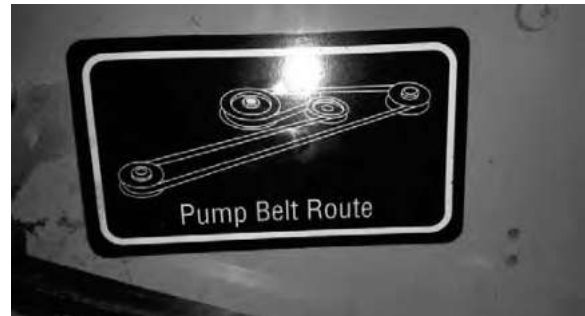

Use a belt tension gauge to ensure the proper tension. Your dealer or service center will have belt tension gauge or you can buy one from the Bad Boy Parts Department by calling 866-622-3269 and asking for the Parts Department. (Part Number 041-9999-00)

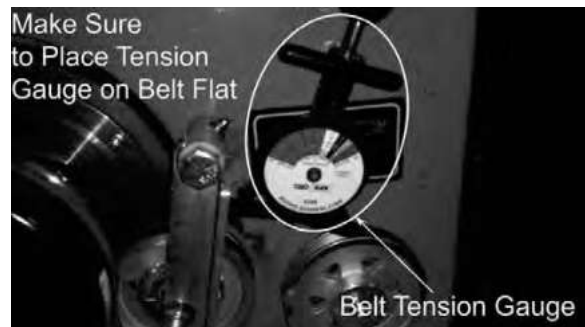

SECTION 3: ENGINE

1500CC DIESEL

On the right is an overview of the 1500cc Diesel Engine. To access the engine, remove the knob on top of the engine cover plate. The oil drain plug is located on the bottom of the engine. Bad Boy recommends that the oil and filter be changed after the initial first 8 hrs of use, and at intervals of 250 usage hours or yearly, whichever occurs first after that. The oil capacity is approximately 4.64 quarts. Cat Diesel Engine Oil 15W-40 is recommended for maximum protection.

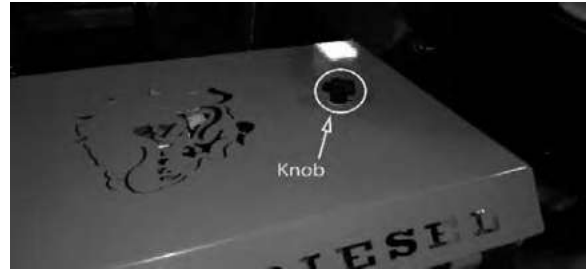

CHANGING YOUR ENGINE OIL AND OIL FILTER

1. After the engine has been run at the normal operating temperature, stop the engine.
2. Remove the oil drain plug located underneath the engine. Allow the oil to drain into a drain pan. After the oil has drained, the oil drain plug should be cleaned and installed.
3. Remove the oil filter.
4. Check the oil filter for any metal debris that may indicate engine wear.
5. Clean the sealing surface of the cylinder block.
6. Apply clean engine oil to the new oil filter seals.
7. Install the oil filter. Tighten the oil filter until the oil filter seal contacts the cylinder block. Do not overtighten the oil filter.
8. Remove the oil filler cap. Fill the crankcase with approximately 5.91 quarts of oil. When refilling be careful not to overfill the crankcase.
9. Start the engine and run the engine at "LOW IDLE" for two minutes. Perform this procedure in order to ensure that the lubrication system has oil and that the oil filters are filled. Inspect the oil filter for leaks.
10. Stop the engine and allow the oil to drain back to the sump for a minimum of ten minutes.
11. Remove the oil level gauge in order to check the oil level. Maintain the oil level between the "ADD" and "FULL" marks on the oil level gauge.

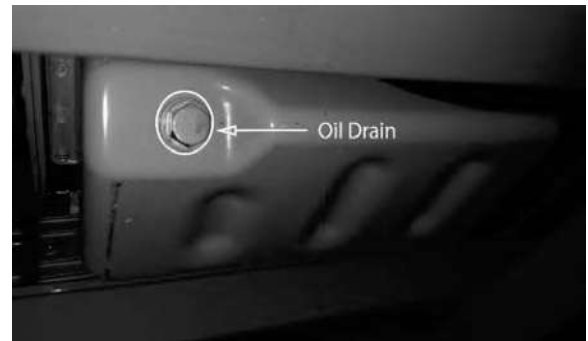
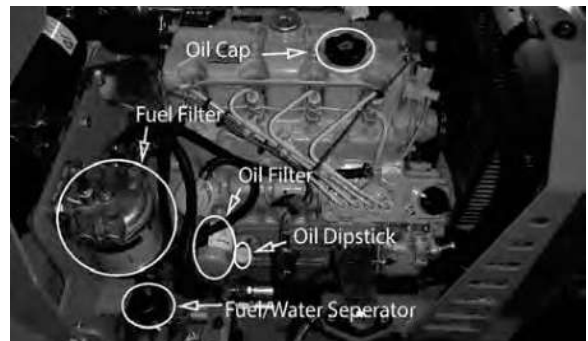



1500CC DIESEL (CONTINUED)

When servicing the fuel system on the Diesel, it is necessary to purge the air from the system by loosening the 9/16" bolt on top of the fuel filter and pumping the fuel bulb (located underneath the radiator) until air bubbles are no longer visible.

CHANGING YOUR FUEL FILTER

1. Your 1100cc Diesel has two fuel system filters. The first is a filter/water separator.
2. Open the drain on the bottom of the filter/water separator. Catch the draining fluid in a suitable container. Dispose of the drained fluid correctly.
3. Close drain.
4. The second fuel filter is a canister located above the fuel/water separator.
5. Close the fuel supply valve.
6. Clean the outside of the fuel filter assembly.
7. Remove the filter housing bolt from the bottom of the filter.
8. Remove the canister. Ensure that any fluid is drained into a suitable container.
9. Assemble the following items: seals (8), seal (7), canister (3), and bowl (10). Place washer (5) and seal (6) on setscrew (2).
10. Fasten the assembly to the fuel filter base with housing bolt (2).
11. The fuel system will need to be primed after the new filter is installed. Refer to air purging instructions at top of page.

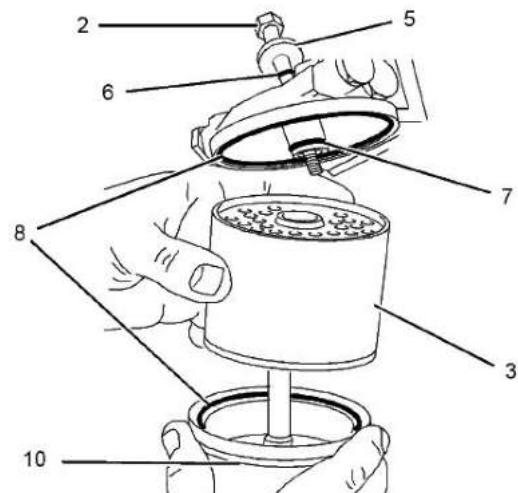

1500CC DIESEL (CONTINUED)

Remove and inspect air cleaner weekly. (More often in dusty conditions). Do not blow filter out with air pressure, this will cause the filter to be filled with tiny holes that will allow dirt to enter. Instead, tap filter on side to remove any debris. Replace at least once a year, more often in dusty conditions.

CHANGING THE AIR CLEANER

1. The air filter is located on the back of the mower. Unlatch the four latches that hold the cap onto the filter housing.
2. Remove the outer air element and inspect it. If it is dirty it might be necessary to use low air pressure to clean it out (30psi or less). Higher air pressure can damage the pleats.
3. Clean or replace both the inner and outer air elements.
4. Reattach the cap onto the filter housing.

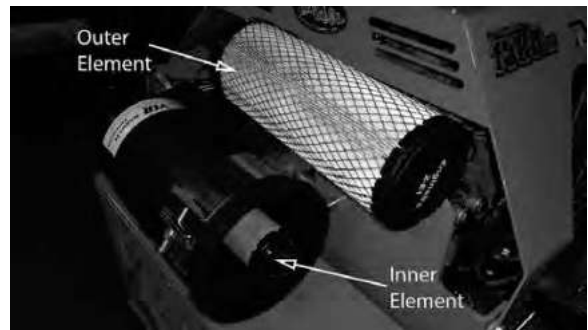
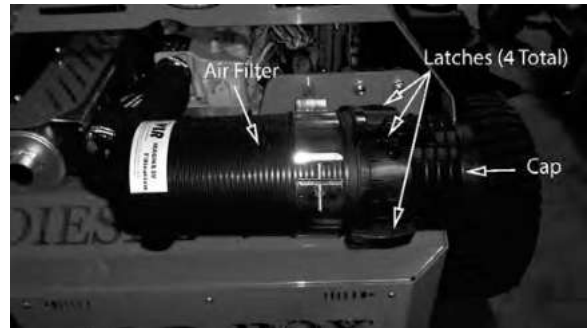

Torque the clutch bolt to 50 ft.-lbs. on all models. Retorque at every oil change.

Keep radiator screen clean and free of debris on liquid cooled models. Check screen hourly during dry conditions. Slide radiator screen up to remove.

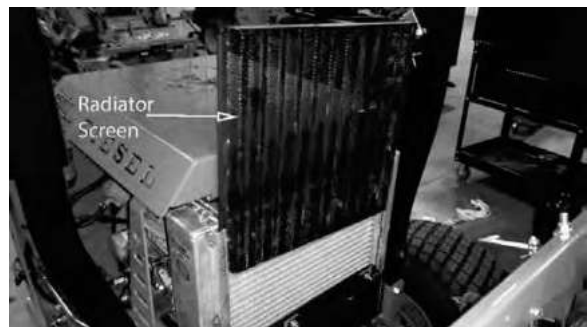



SECTION 4: ELECTRICAL SYSTEM

The fuses on the 1100cc Diesel are located behind the left swing away tank. The top 40-amp fuse is the main fuse and the two 15-amp fuses are for the linear actuator and for the clutch.

Always check the condition of the wiring harness ground cable. Ensure that the ground is connected, clean, and tight. On most models, the ground wire is connected to the negative side of the battery.

Check the condition and connection of the relays. Two relays are located behind the left swing away tank and the other 5 are located behind the right swing away tank. Ensure that they are clean and connected. Make sure that wire terminal ends have not been pushed out of the relay block.

On most models, the red wire coming out of the engine is the charging wire from the alternator. Check for 13.6—14.2 volts DC at this wire with engine at full throttle.

The linear actuator is the mechanism that raises and lowers the deck. If it ever starts to make noise when raising and lowering the deck you might find it necessary to tighten the nuts and bolts on the front and rear of the actuator. Be careful not to overtighten these as you can damage the actuator. Also, if your actuator ever stops working make sure to check the main fuse or the linear actuator fuse.

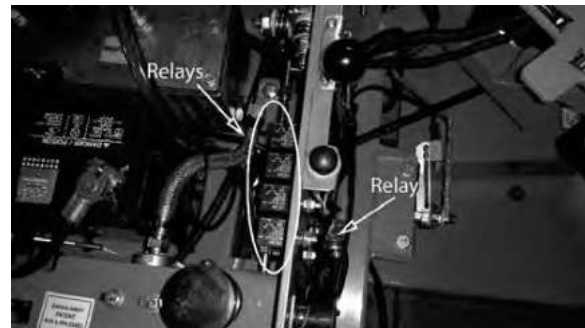
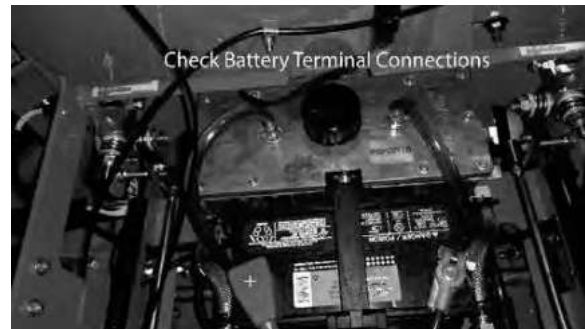
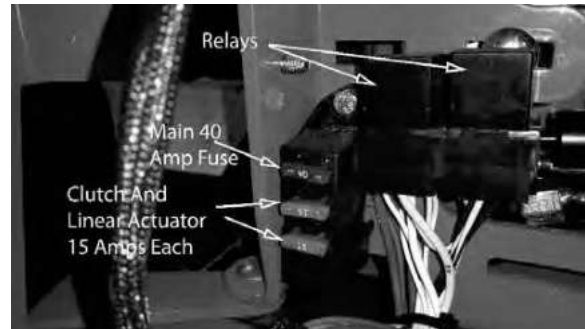



ELECTRICAL SYSTEM (CONTINUED)

WIRING DIAGRAM

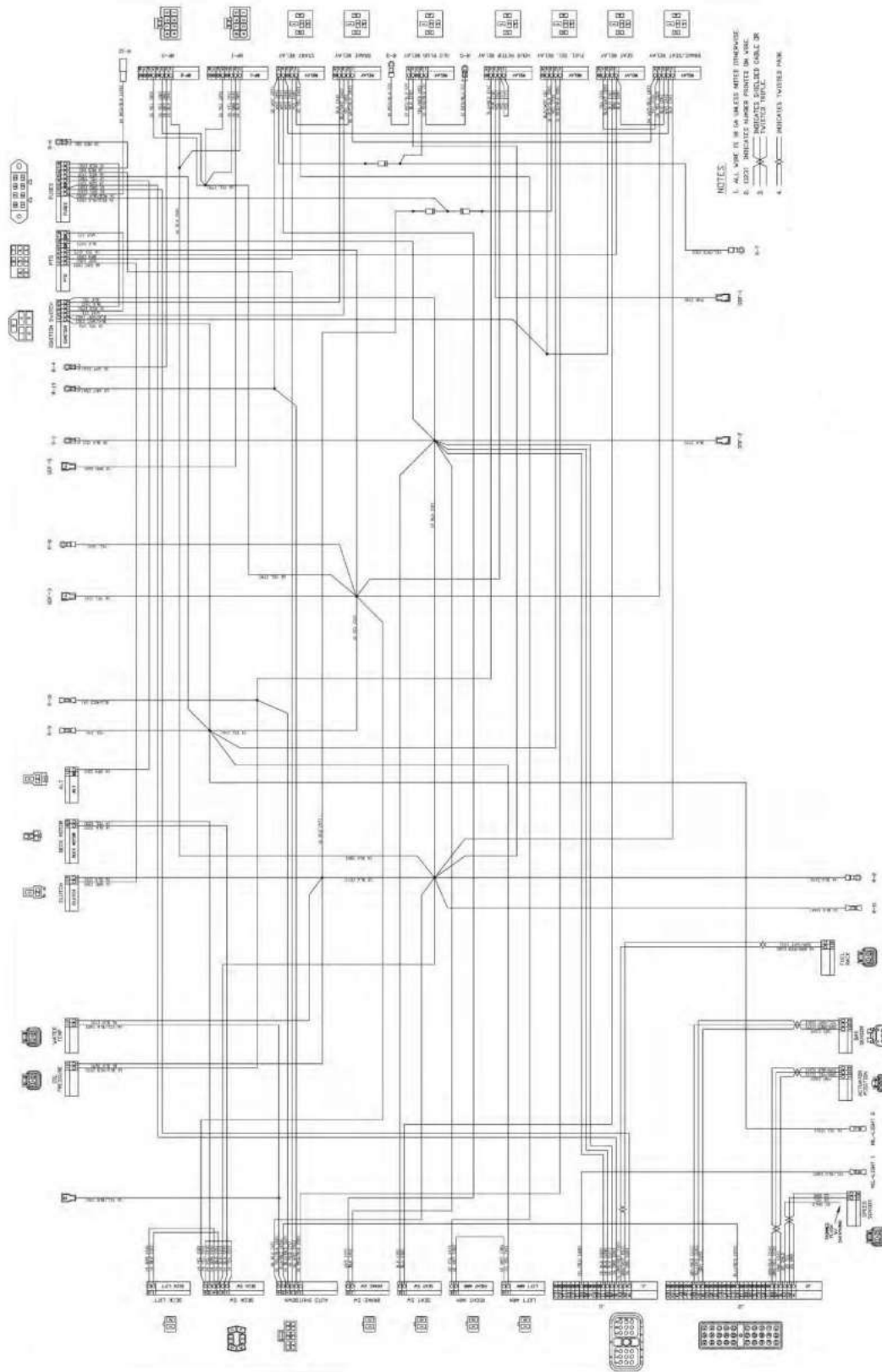



SECTION 5: FRAME

The front fork nuts require a torque of 40ft-lbs. First remove the dust cap. While applying this torque, turn the fork itself to ensure no damage is done to the bearing. This operation is only necessary if a repair requires it.



Torque rear wheel lugs to 65-75ft. lbs. Re-torque at every oil change and check every morning.

There are two grease zerks located on each of the two turnbuckles (4 Total). Grease at every oil change.



The pump belt tensioner is located under the engine and has a grease fitting at its pivot point. Grease at every engine oil change.

The deck belt tensioner is located at the rear of the deck and has a grease fitting on its pivot point. Grease at every engine oil change.



The control arm blocks have grease fittings located on the top of each block. Grease one time a year.



If the T-Handle stops working open the swing away tank and check to see if the collar is still in the bracket. If not place the collar back into the T-Handle.

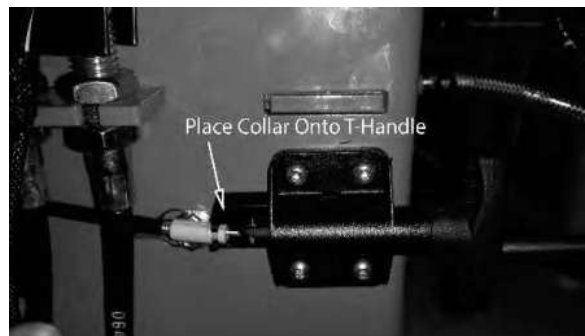

SECTION 6: CUTTING DECK

DECK BELT REMOVAL

1. Use proper safety precaution when performing procedures.
2. Raise the deck to its highest position.
3. Remove the right pulley cover.
4. While lifting up on the belt (as shown in the photograph), rotate the pulley until the belt is free of the pulley. Exercise caution while performing this step as fingers can easily become caught between the belt and pulley.



DECK BELT INSTALLATION

1. Use proper safety precaution when performing procedures.
2. Raise the deck to its highest position.
3. Take off both pulley covers and route the belt by following the belt route decal.
4. Verify that the belt is routed properly as improper routing can damage the spindles as well as the engine, and immediately ruin the belt.

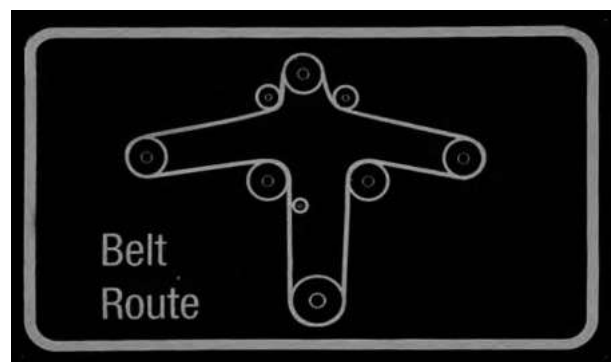
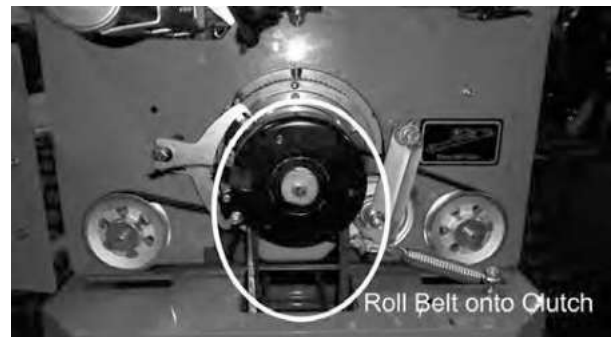



LEVELING THE DECK

1. Start on a flat level surface and set the air pressure in all four tires to 12 psi. Measure the deck at all four corners. The deck should be level from left to right but 1/4" lower in the front than in the rear. adjustments can be made by adjusting the deck hangers in their slots.
2. Using a pair of approximately 3 ft. long 2x4's, stand the boards on edge and slide them under the deck from front to back as shown.
3. Remove the foot pedal and raise the floor plate. Remove one end of the deck lift spring assist dampener using a pair of 1/2" wrenches as shown.
4. Lower the deck down onto the 2x4's and install the deck height pin into its highest available hole. This should be relatively close to the width of the 2x4 boards.
5. Using a pair of 3/4" wrenches, loosen all deck hanger bolts on the top of the deck. These are the lower bolts in the slots of the deck as shown. Do not loosen the upper bolts that attach the deck hangers to the actuator lift bars.
6. The deck is now loose from the frame and movement of the lift pedal should only move the hanger bolts up and down in the deck slots. at this point a different deck height adjustment pin location may be chosen. choosing a lower number will raise the decks cutting height. choosing a higher number will decrease the decks overall cutting height. Remember, you should be approximately in the 3.5" range on your selection.
7. You may now tighten all of the deck hanger bolts in the deck slots starting with the rear first, then the front. Lift the deck to the highest position. measure all four corners of the deck again to ensure that no further adjustments are necessary. reattach the deck lift assist dampener with the pedal pressed to its maximum travel. this may require assistance from another person to achieve.
8. Close the floor plate and reattach the foot pedal. check belt tension before mowing.

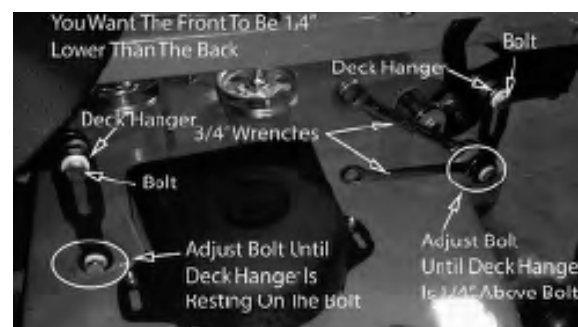
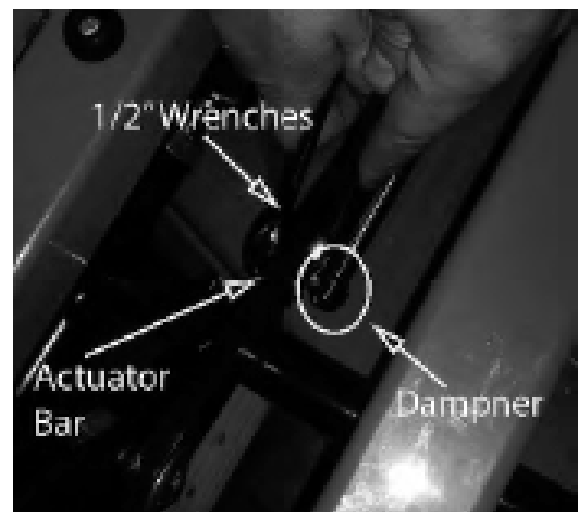
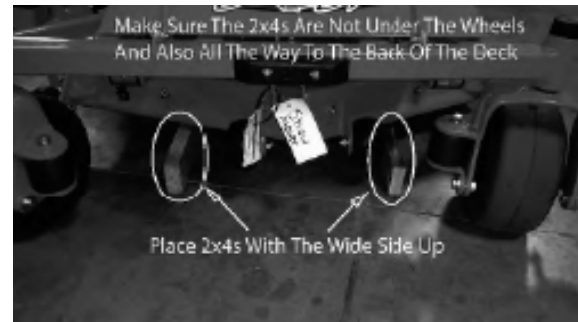

ADJUST DECK BELT TENSION

The deck spring tension is critical. If the tension is too high, premature failure of the deck belt and blade spindles can occur. If the tension is too low, the belt can "jump off" or slip on the pulleys. This results in reduced cut quality and early belt failure.

Spring tension adjustments can be made by sliding the bolt shown above forward or backward in the slot of the deck. Belt tension should be 60-65 lbs. with the deck at its lowest setting.

Use a belt tension gauge to ensure the proper tension. Your dealer or service center will have a belt tension gauge or you can buy one from the Bad Boy Parts Department by calling 866-622-3269 and asking for the Parts Department. (Part Number 041-9999-00).

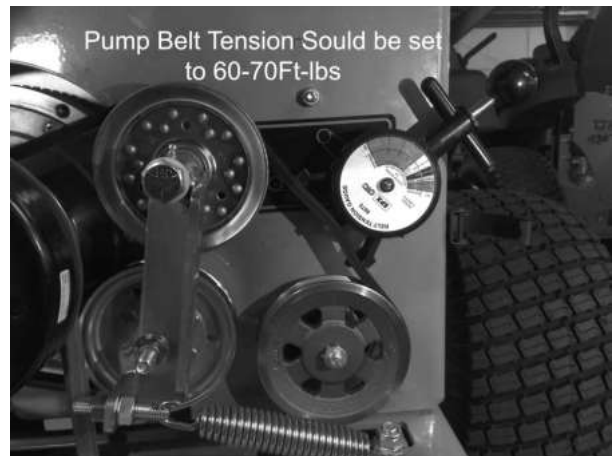
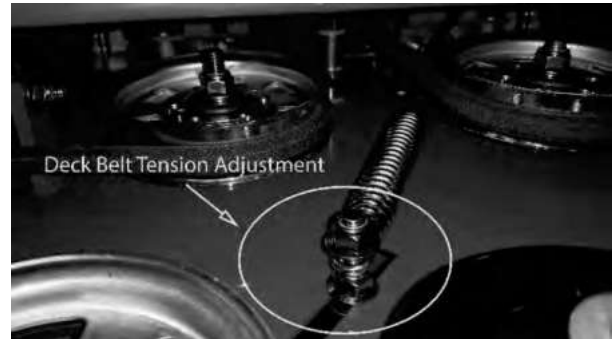

Unlatch the back cover to access the pump belt. The pump belt tension should be 60-70ft-lbs.

BLADE SHARPENING

The blade on the top (see photo) was utilized long after replacement was required. In addition to a decline in cut quality, failure to replace a worn or damaged blade creates a major safety hazard. Bad Boy recommends that blade sharpening be performed by a professional.





BLADE REMOVAL

To change blades, it may be easier to use a piece of wood to keep the blade from turning so that the bolt can be loosened. Use a 15/16" socket and impact drill, or a wrench and an extension to gain more leverage. You might need to put a 3/4" wrench on top of the pulley bolt to keep the blade from spinning. Bolts used have right-handed threads.

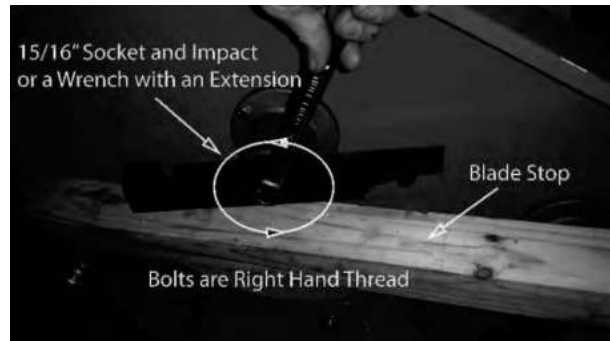

Re-torque the blade bolts to 90-110 lbs.

The blade spindles contain a sealed ball bearing inside the top and bottom of the spindle. The bearings are replaceable for a more cost-effective repair.

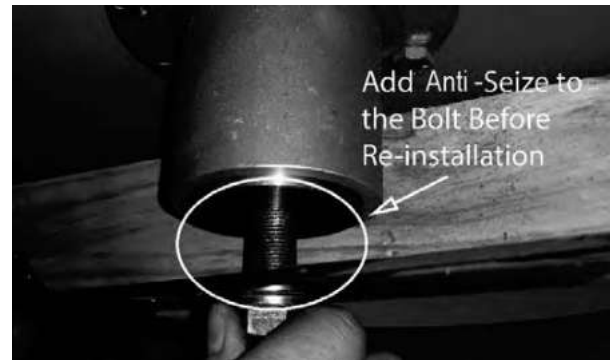





PARTS SECTION: DIESEL SUSPENSION FORK ASSEMBLY

Parts List				Parts List			
ITEM	QTY	PART NUMBER	DESCRIPTION	ITEM	QTY	PART NUMBER	DESCRIPTION
1	1	023-0020-00	Suspension Fork Top/Side Combo	15	1	012-7003-00	Seal
2	1	023-0012-00	Suspension Fork - Bottom Left	16	1	013-8050-00	1/2-13 Nylon Flange Nut
3	1	023-0013-00	Suspension Fork - Bottom Right	17	2	025-5203-00	Spacer 3/4 OD x 1/2 ID x 3/4 Length
4	1	037-0010-00	Front Suspension Fork Spindle	18	1	025-5202-00	Front Wheel Spanner
5	2	013-5300-00	1/2" Flange Nut	19	1	018-3002-00	1/2" x 10" Bolt
6	2	018-2030-00	1/2" x 1" Hex Bolt	20	1	013-9004-00	1" Fine Thread 1/2 Nylock Nut
7	4	019-5702-00	1/2" Washer (Grade 8)	21	1	014-7005-00	Dust Cover
8	2	032-9002-00	Vibration Mount- Red Dot	22	2	018-2080-00	1/2" x 1-1/4" Gr5 Hex Bolt (Coarse)
9	1	013-6016-00	1" Fine Thread Nut	23	2	022-7010-00	1-3/4" Bearing-Large Bore Front Rim
10	2	019-3000-00	1" Lock Washer	24	4	019-5007-00	1/2" Lock Washer
11	2	019-5038-00	5/8" Flat Washer	25	1	014-8047-00	Spring Cap Cover
12	2	018-3001-00	5/8" x 5/8" Shoulder Bolt	26	1	022-1050-00	13 x 6.50 - Reliance No-Flat
13	2	032-5052-00	Bronze Bushing - SF - 2024-8	27	1	023-7915-98	Suspension Fork Assembly
14	2	010-7001-00	Bearing	28	1	022-1050-00	13 x 6.50 - No-Flat Large Bore Orange front Assembly

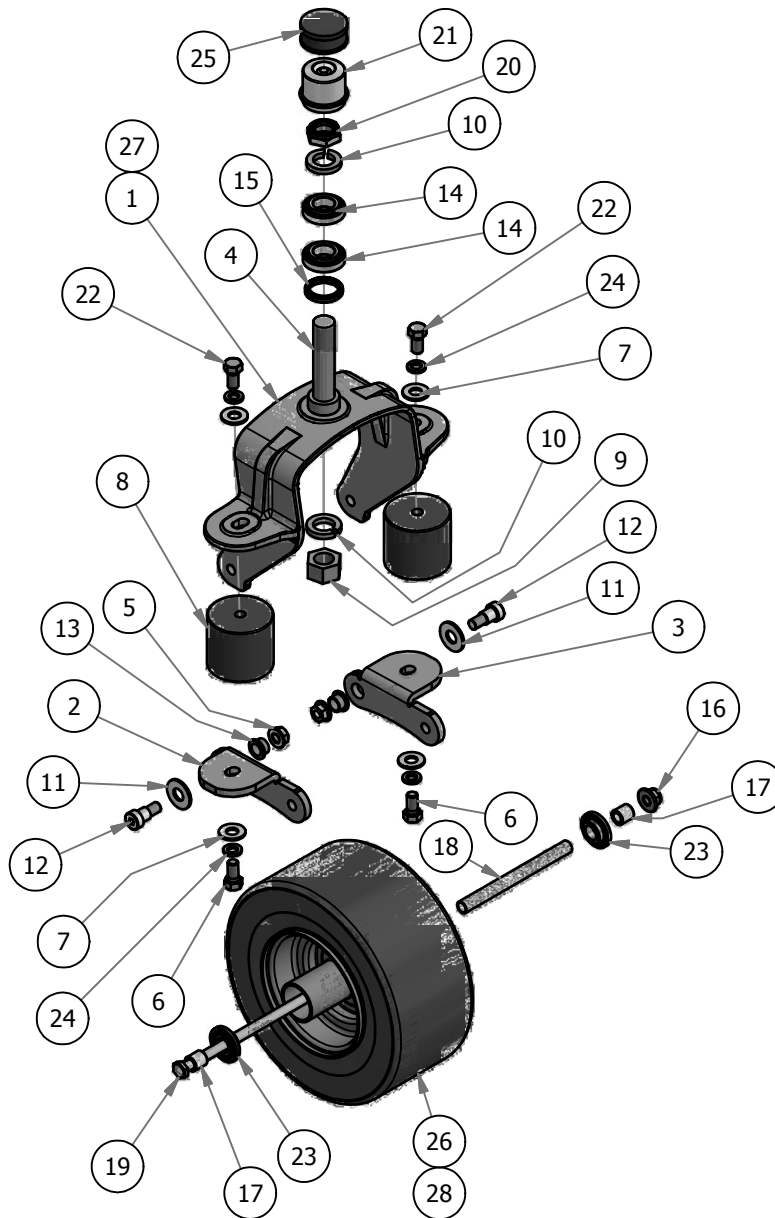

PARTS SECTION: 1100CC DIESEL DRIVE ARMS

Parts List				Parts List			
ITEM	QTY	PART NUMBER	DESCRIPTION	ITEM	QTY	PART NUMBER	DESCRIPTION
1	4	034-8025-00	Drive Lever Spring	26	2	099-6046-00	3/8-24 Ball Joint
2	8	019-8027-00	.515 ID Nylon Shoulder Washer	27	2	019-5702-00	1/2" Washer (Grade 8)
3	2	024-6034-00	1/4" Press in Grease Fitting	28	1	027-2017-00	Steering Block Assembly - Right
4	2	013-8050-00	1/2-13 Nylon Flange Nut	29	2	018-4011-00	3/8-24 Nylon Insert jam locknut
5	2	013-8043-00	5/16" Nut	30	1	027-2018-00	Steering Block Assembly - Left
6	2	018-8063-00	5/16" x 3/4" Hex Bolt	31	6	019-6017-00	.630 ID Plastic Washer
7	6	013-6051-00	3/8" Fine Threaded Jam Nut				
8	2	019-5037-00	3/8" Lock Washer				
9	2	069-4010-00	Black Steering Grip				
10	2	045-5000-00	Black Knob for Adjustable Steering Arm				
11	1	031-9015-70	Lower Adjuster - Steering Arm- Right				
12	2	031-9010-00	Upper Tube-Adjustable Steering				
13	1	031-9016-70	Upper Adjust Steering Arm- Right				
14	8	018-2020-00	5/16-18 1/2 HWH Bolt-Steering				
15	1	031-9025-70	Steering Arm Elbow (Right)				
16	4	013-9002-00	5/16" Flange Nut				
17	4	018-2050-00	10mm Damper Ball Stud-Steering				
18	2	013-0085-00	1/2-13 Hex Flange (GR.G) ZC				
19	2	087-8080-00	Steering Damper				
20	1	031-9017-70	Upper adjuster-Steering Arm- Left				
21	1	031-9014-70	Lower Adjuster - Steering Arm- Left				
22	2	018-5043-00	3/8" x 1 1/4" Carriage Bolt				
23	1	031-9020-70	Steering Arm Elbow (Left)				
24	2	035-6060-00	1100cc Diesel Push Rod				
25	2	099-2009-00	Quick Release Ball Joint				

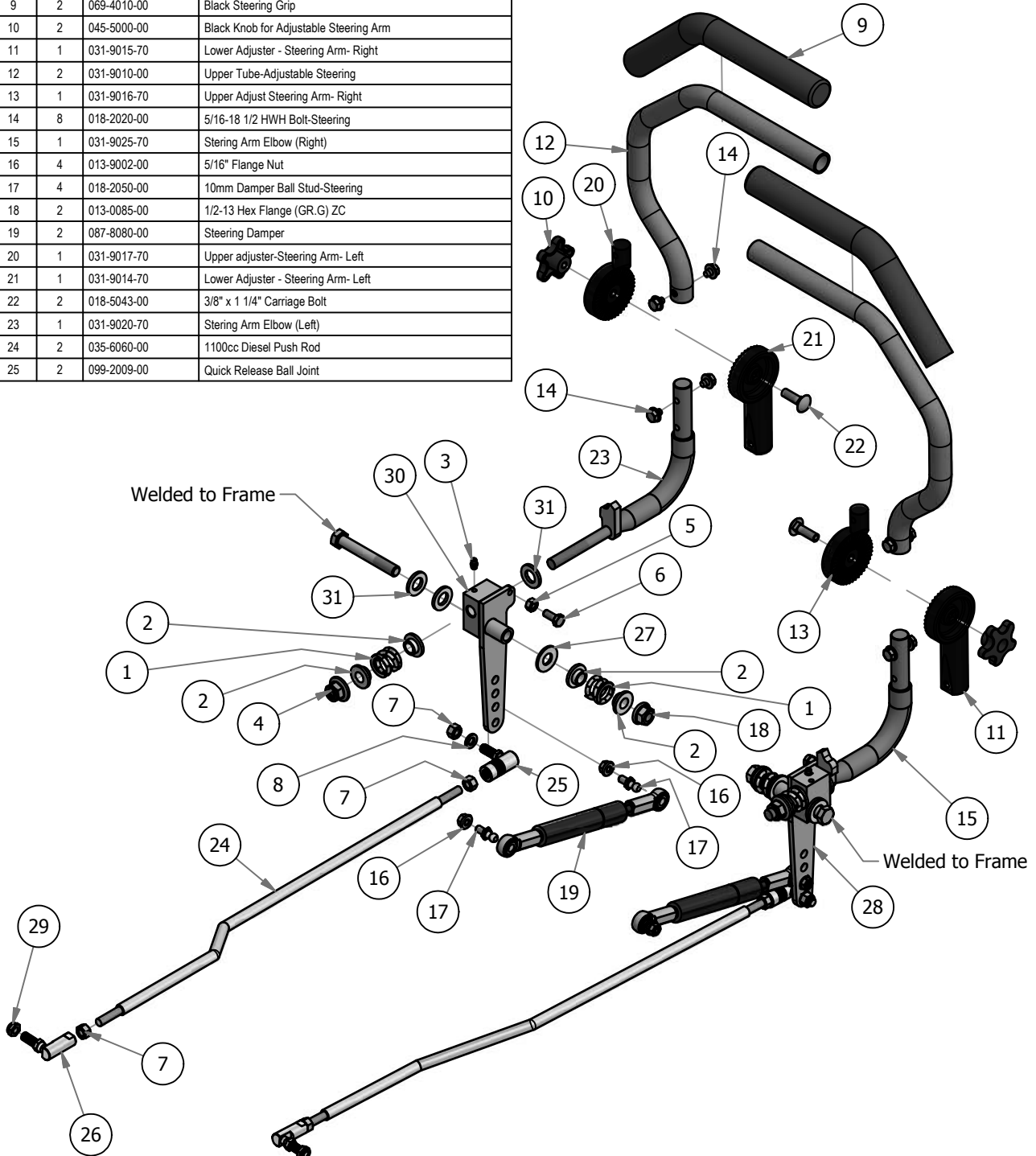



PARTS SECTION: 1100CC DIESEL TANKS

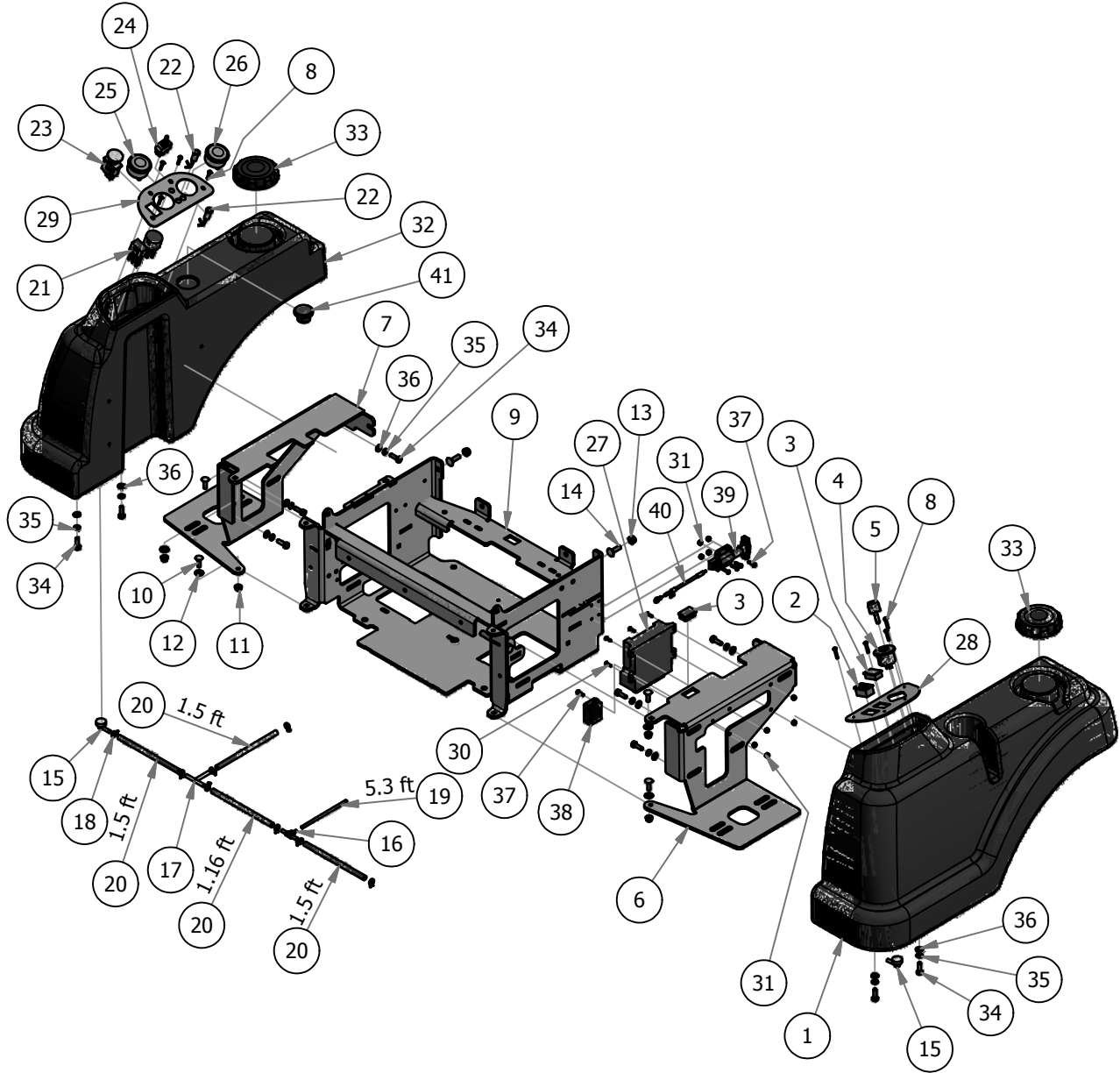



PARTS SECTION: 1100CC DIESEL TANKS

Parts List			
ITEM	QTY	PART NUMBER	DESCRIPTION
1	1	067-3000-00	Left Fuel Tank with Fender
2	1	083-4014-00	Hour Meter
3	2	018-1040-00	Light Plug
4	1	077-8076-00	Ignition Switch
5	1	042-9000-00	Ignition Key
6	1	031-2010-00	Tank Supports-Left
7	1	031-2011-00	Tank Support- Right
8	8	018-2015-00	10-32 x 1 Button Head Bolt
9	1	080-6010-00	Diesel Seat Frame
10	4	018-8065-00	5/16" x 1" Carriage Bolt
11	4	013-9002-00	5/16" Flange Nut
12	4	019-6042-00	.360 ID Plastic Washer
13	2	013-5202-00	3/8" Nylock Flange Nut
14	2	018-5043-00	3/8" x 1 1/4" Carriage Bolt
15	2	067-6055-00	Fuel Tank Hose Nipple w/ Filter
16	1	073-2000-00	Brass fuel line T
17	1	073-8068-00	fuel line T
18	8	072-8069-00	1/4 Fuel Hose Clamp
19	5.3 ft	051-8068-00	3/16 Fuel Line
20	5.66 ft	051-8067-00	1/4" Fuel Line Hose
21	1	086-0247-00	Wiring Harness
22	2	089-1000-00	Oil Light
23	1	056-8058-00	PTO Engager
24	1	078-8077-00	Deck Lift Joystick
25	1	086-7001-00	2" Water Temperature Gauge
26	1	086-7000-00	2" Oil Pressure Gauge
27	1	015-4010-00	ECM for 1100cc Diesel
28	1	079-3402-00	Control Panel (Left)
29	1	079-3406-00	1100cc Diesel Control Panel
30	4	018-5200-00	10-24 X 5/8 BS Button Head Bolt
31	9	013-5019-00	10-24 Nylon Insert Locknut Zinc Orange Nylon
32	1	067-3001-00	Right Fuel Tank with Fender
33	2	066-8090-00	Diesel Fuel Cap - 3.5" Neck
34	10	018-2007-00	5/16" x 1" Bolt
35	10	019-8051-00	5/16" Lock Washer
36	10	019-8044-00	5/16" Flat Washer
37	5	018-8058-00	10-24 x 1 BS C/S 18-8 SS
38	1	015-0015-00	Auto Shut Down for Cat Diesels
39	1	039-2016-00	2016 T Handle Release
40	1	064-0002-00	2015 Seat Latch Cable
41	1	067-4025-00	Fuel Gauge and Grommet



PARTS SECTION: 1100CC DIESEL FRAME

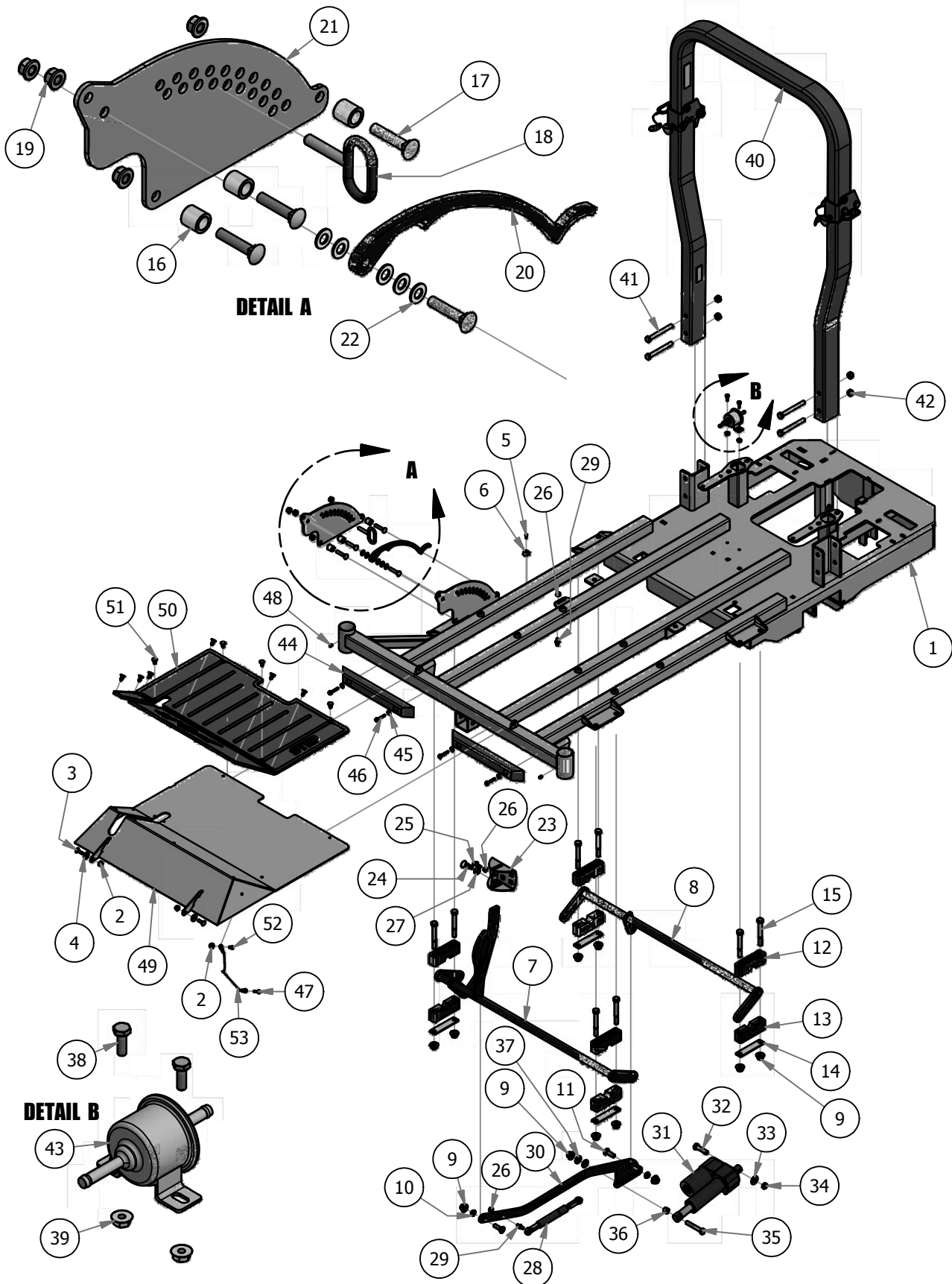



PARTS SECTION: 1100CC DIESEL FRAME

Parts List			
ITEM	QTY	PART NUMBER	DESCRIPTION
1	1	070-5580-00	Outlaw Diesel Frame
2	3	013-8049-00	5/16-18 Nylon Flange Nut
3	2	018-8065-00	5/16" x 1" Carriage Bolt
4	2	019-6042-00	.360 ID Plastic Washer
5	8	030-3050-00	#10 x 1/2" Self Tapping Screw
6	8	029-4010-00	Button Bumper
7	1	028-6030-00	2015 Outlaw Act Bar Assembly (Front)
8	1	028-6040-00	2015 Outlaw Act Bar Assembly (Rear)
9	11	013-8050-00	1/2-13 Nylon Flange Nut
10	2	032-3000-00	Bushing- SF-1620-4
11	2	018-0008-00	1/2 x 1-1/2 Carriage Bolt
12	4	017-9000-00	Two Piece Pillow Block (Male)
13	4	017-9050-00	Two Piece Pillow Block (Female)
14	4	017-9025-00	Two Piece Pillow Block Strap
15	8	018-5019-00	1/2" x 4" Bolt (Grade 8)
16	3	025-5203-00	Spacer 3/4 OD x 1/2 ID x 3/4 Length
17	4	018-0009-00	3/8 x 1 3/4 Carriage Bolt
18	1	040-4000-00	Deck height lever pin
19	4	013-5202-00	3/8" Nylock Flange Nut
20	1	031-0100-00	Outlaw Deck Lever Lock
21	1	026-2100-00	Outlaw Height Indicator Plate (Outer)
22	5	019-2003-00	.390 x .750 x .062 Nylon Washer
23	1	026-0013-00	Outlaw Deck Lift Pedal
24	1	040-5000-00	Pull Pin
25	1	030-0010-00	5/16-18 x1 Thumb Screw Zinc
26	3	013-9002-00	5/16" Flange Nut
27	1	013-7018-00	1/2" Hex Nut
28	1	087-6100-00	250lb Gas Spring
29	2	018-2050-00	10mm Damper Ball Stud-Steering
30	1	028-6055-00	Outlaw Linkage Bar Susp Frame
31	1	035-7033-00	Actuator
32	1	018-0022-00	1/2-13x2 Grade 8 Hex Bolt
33	1	019-5702-00	1/2" Washer (Grade 8)
34	1	018-4010-00	1/2" Nylock Nut (1/2 Jam)
35	1	018-7016-00	1/2" x 3" Hex Bolt
36	1	025-7036-00	1/2 x 1/2 Spacer
37	2	019-8054-00	.505 Nylon Spacer
38	2	018-8052-00	1/4" x 3/4" Hex Bolt
39	2	013-9001-00	1/4-20 Hex Flange Nuts Zinc w/Serrations
40	1	089-0003-00	2014 & Newer Diesel 2x3 Folding ROPS
41	4	018-7050-00	1/2" x 4 1/2" Bolt
42	4	013-0005-00	1/2" Center Lock Nut
43	1	015-4000-00	Electric Fuel Pump
44	2	029-7037-00	14" Rubber Bumper
45	4	019-7040-00	1/4" Flat Washer
46	4	030-7039-00	1/4" x 1 1/2" Self Tapping Screw
47	1	030-7040-00	1/4 x 1 Hex Head tek screw
48	2	024-6034-00	1/4" Press in Grease Fitting
49	1	079-3210-00	Compact Diesel Floorboard
50	1	081-2008-00	Foot Assist Floor Mat
51	10	040-6080-00	Ratchet Fastener
52	1	018-8064-00	1/4" x 5/8" BS C/S 18-8 SS
53	1	064-2006-00	Floor board Cable W/ Swivel Ends



PARTS SECTION: 1100CC DIESEL SEAT FRAME

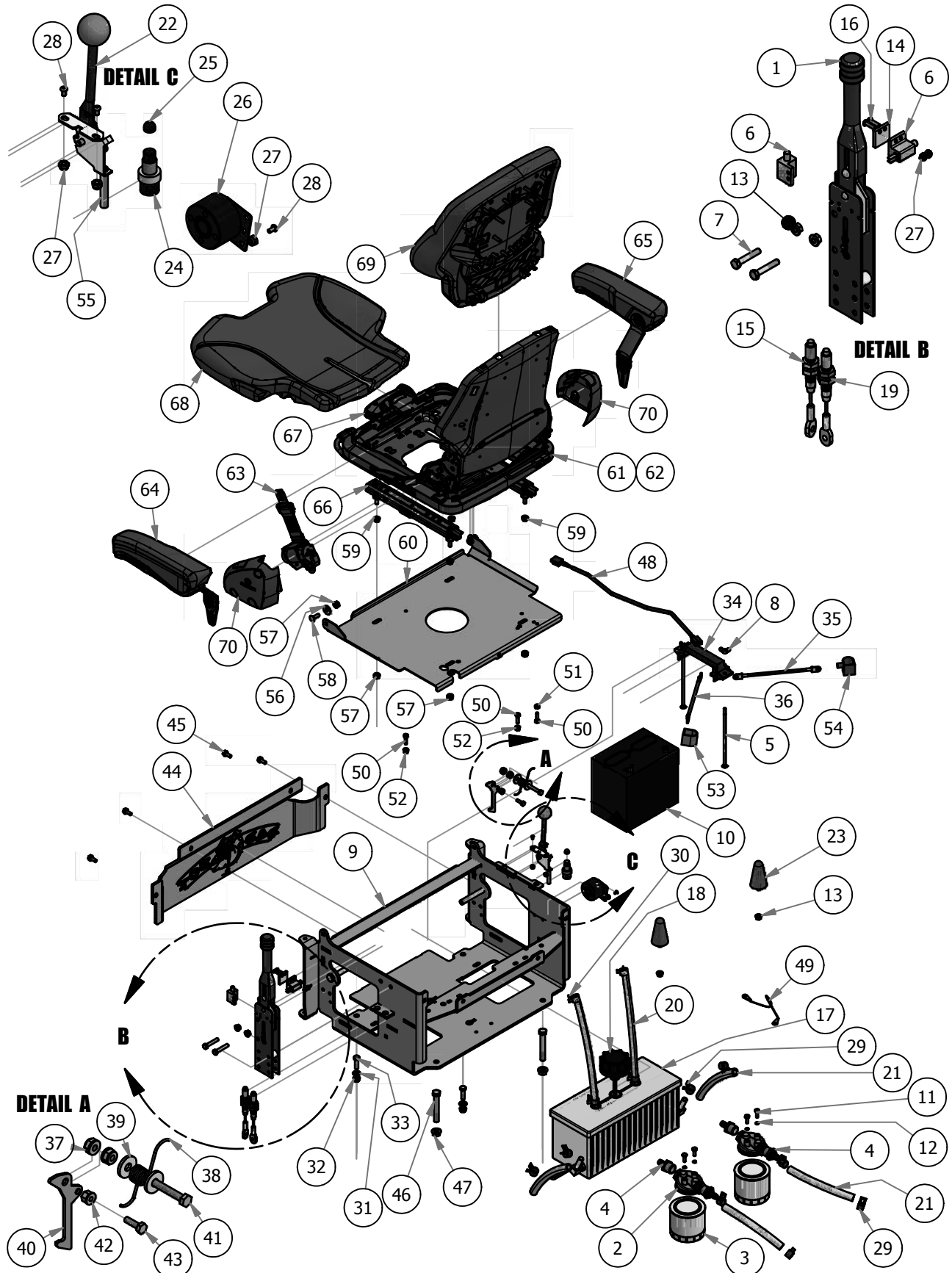



PARTS SECTION: 1100CC DIESEL SEAT FRAME

Parts List				Parts List			
ITEM	QTY	PART NUMBER	DESCRIPTION	ITEM	QTY	PART NUMBER	DESCRIPTION
1	1	069-8054-00	Hand Brake Assembly	37	2	013-8049-00	5/16-18 Nylon Flange Nut
2	2	062-8013-00	Filter Head	38	1	034-1075-00	Torsion Spring for Seat latch
3	2	063-8014-00	Hydraulic filter	39	2	019-6042-00	.360 ID Plastic Washer
4	4	024-5050-00	Filter Head Fitting	40	1	031-0200-00	Seat Latch Lever
5	2	018-8051-00	1/4-20 X 9 Carriage Bolt	41	1	018-0012-00	5/16-18 X 2 Hex C/S (GR.5) ZC
6	3	077-8073-00	Switch	42	1	013-2050-00	1/4-20 Nylon Insert flange Nut
7	2	018-8059-00	5/16" x 1 3/4" Hex Bolt	43	1	018-4702-00	1/4-20 x 1-1/4 GR 5 Hex Bolt
8	2	013-8051-00	1/4" Wing Nut	44	1	014-2009-00	Cooler Cover
9	1	080-7000-00	2007 Diesel Seat Frame	45	4	030-7042-00	5/16 x 3/4 washer head type F screw
10	1	068-8050-00	Battery - Diesel Models - I51	46	2	018-2018-00	1/2 x 3 1/2 Flange Bolt Grade 8
11	4	018-8052-00	1/4" x 3/4" Hex Bolt	47	2	013-5300-00	1/2" Flange Nut
12	5	019-4008-00	1/4" Lock Washer	48	1	070-2005-00	Seat Switch Adapter
13	4	013-9002-00	5/16" Flange Nut w/Serrations	49	1	064-8081-00	Seat Cable
14	2	025-6041-00	Switch Block Plastic	50	3	018-4007-00	1/4-20 x 1 GR 5 hex bolt zinc
15	1	064-8055-00	Short Brake Cable	51	1	013-8073-00	1/4 Nylock Nut
16	4	018-8056-00	1024 x 1" Allenhead Bolt	52	2	013-2050-00	1/4-20 Nylon Insert flange Nut
17	1	067-2010-00	Aluminum Hydraulic Tank	53	1	103-5300-00	Red Boot
18	1	066-8050-00	Hydraulic Tank Cap	54	1	103-5400-00	Black Boot For Ground Cable
19	1	064-8056-00	Long Brake Cable	55	1	055-8018-75	Diesel Throttle Cable Only
20	2	051-8063-02	3/8" x 32" Clear Hose	56	2	019-6042-00	.360 ID Plastic Washer
21	4	051-8064-09	1/2" x 9 1/4" Braided Hose	57	6	013-8049-00	5/16-18 Nylon Flange Nut
22	1	055-2012-00	Universal Throttle Head	58	2	018-8065-00	5/16" x 1" Carriage Bolt
23	2	034-1000-00	Spring Cushion	59	4	013-9002-00	5/16" Flange Nut
24	1	077-6000-00	Momentary Start Switch	60	1	026-2006-00	Seat Plate
25	1	014-6000-00	Start Switch Boot - Diesel	61	1	071-4055-17	Grammer Seat With Seatbelt
26	1	021-8059-00	Heat Warning Piezo Buzzer	62	1	071-4060-00	Grammer Seat Black and Orange
27	7	013-5019-00	#10 Nylock Nut	63	1	071-4053-00	Grammer Seat Belt Kit
28	3	018-5200-00	1024 X 5/8" Buttonhead Bolt	64	1	071-4051-00	Left Armrest Kit for Grammer Seat
29	8	072-8066-00	1/2 Hose Clamp	65	1	071-4052-00	Right Armrest Kit for Grammer Seat
30	4	072-8065-00	3/8 hose clamp	66	1	071-4054-00	Rails for Grammer Seat (Pair)
31	2	019-5029-00	3/8" Flat Washer	67	1	071-4059-00	Grey Handle Assembly for Grammer Seat
32	2	013-5201-00	3/8" Flange Nut	68	1	071-4071-00	Black Seat Cushion for Grammer Seat
33	2	018-5040-00	3/8" x 1 1/4" Hex Bolt	69	1	071-4072-00	Black Back Cushion for Grammer Seat
34	1	043-8929-00	Battery Hold Down	70	1	014-4050-00	Black Plastic Side Covers for Grammer Seat
35	1	064-4001-00	Black Battery Cable - Diesel	71	1	071-4056-00	Seat Safety Switch (Not Shown)
36	1	064-4000-00	Red Battery Cable - Diesel				



PARTS SECTION: 1100CC PUMP PLATE ASSEMBLY

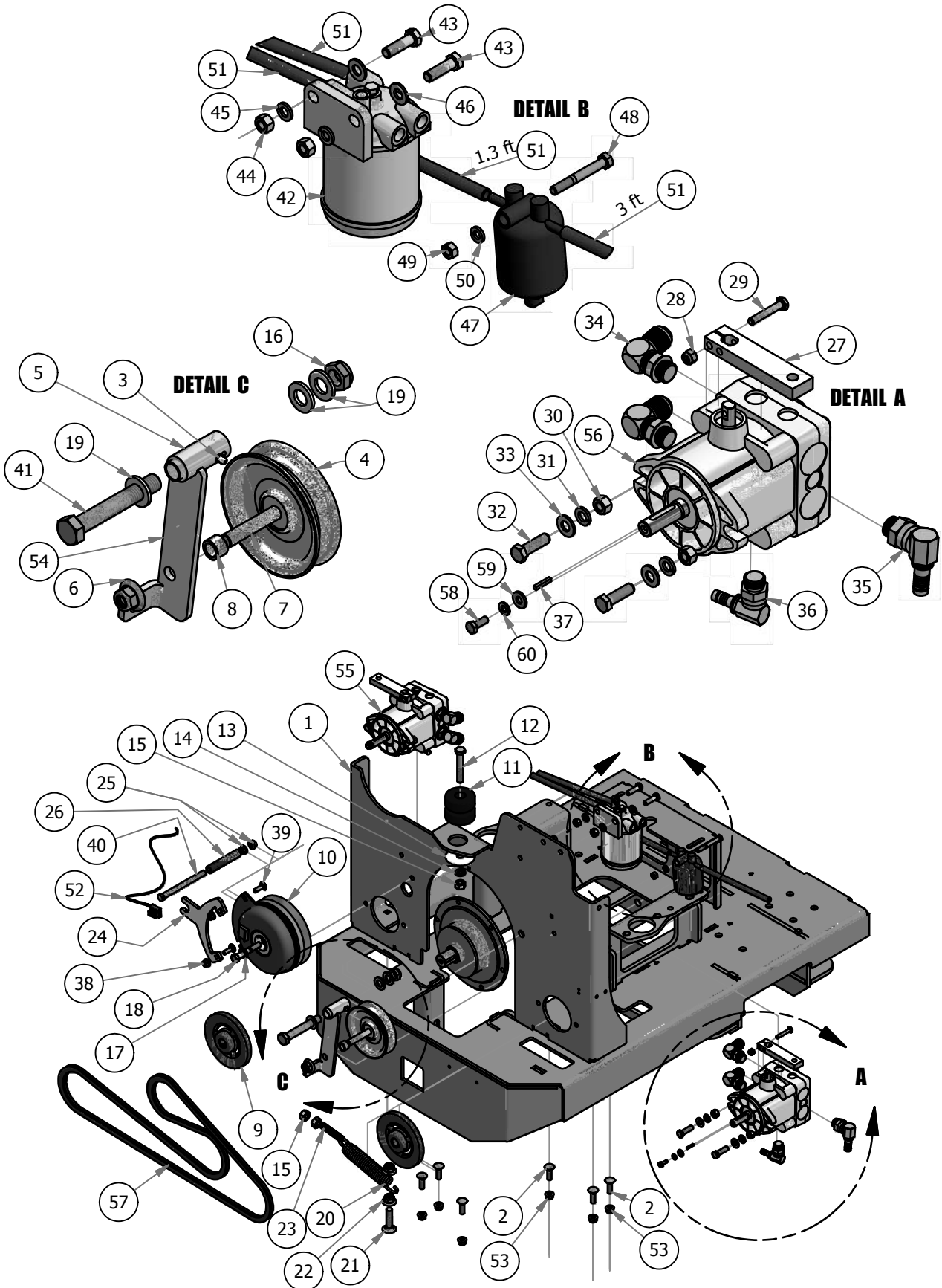



PARTS SECTION: 1100CC PUMP PLATE ASSEMBLY

Parts List				Parts List			
ITEM	QTY	PART NUMBER	DESCRIPTION	ITEM	QTY	PART NUMBER	DESCRIPTION
1	1	026-8030-00	Pump Plate Diesel	31	4	019-5037-00	3/8" Lock Washer
2	6	018-5043-00	3/8" x 1 1/4" Carriage Bolt	32	4	018-6012-00	3/8" x 1 1/2" Hex Bolt
3	1	024-3050-00	1/4" Drive in Grease Fitting	33	4	019-5029-00	3/8" Flat Washer
4	1	033-6001-00	4 3/4" Idler Pulley	34	4	024-2060-00	6801-LL-8-8 Fitting - Compact Diesel
5	1	039-5950-00	Pump Idler Bracket only for 61" Deck	35	2	024-5002-00	90 Degree Fitting 1/2" x 3/4" 4601-8-8
6	1	013-8050-00	1/2-13 Nylon Flange Nut-Orange	36	2	024-5206-00	90 Degree Fitting 3/8" X 9/16"- 4601-6-6
7	1	018-7016-00	1/2" x 3" Hex Bolt	37	2	042-5012-00	5mm x 1.25" Key
8	1	025-7036-00	1/2 x 1/2 Spacer	38	2	013-9002-00	5/16" Flange Nut
9	2	033-5011-00	5" Pump Pulley	39	2	018-8065-00	5/16" x 1" Carriage Bolt
10	1	070-5040-00	Clutch Assembly for Diesel	40	1	018-7055-00	3/8-16 x 5 Hex Bolt - Grade 5
11	1	032-4000-00	Armor Plated Mount-Rear Mount	41	1	018-5311-00	5/8" x 4" Hex Bolt 61" Deck only
12	1	018-7016-00	1/2" x 3" Hex Bolt	42	1	063-2011-00	Fuel Filter
13	1	032-4051-00	Snubbing Washer	43	2	018-5040-00	3/8" x 1 1/4" Hex Bolt
14	1	019-5007-00	1/2" Lock Washer	44	2	013-6014-00	3/8" Hex Nut
15	3	013-7018-00	1/2" Hex Nut	45	2	019-5037-00	3/8" Lock Washer
16	1	013-5301-00	5/8" Nylock (1/2 Jam)	46	2	019-5029-00	3/8" Flat Washer
17	1	019-8053-00	7/16" Lock Washer	47	1	015-0007-00	Caterpillar Fuel Bowl Kit
18	1	018-5401-00	7/16" x 2 3/4" Fine Thread Bolt	48	1	018-5344-00	5/16" x 2 1/2" Bolt
19	3	019-6017-00	.630 ID x 1.122 OD x .142 THK Plastic Washer	49	1	013-8043-00	5/16" Nut
20	1	034-2009-00	Deck Idler Spring	50	1	019-8051-00	5/16" Lock Washer
21	1	018-1050-00	1/2 x 2" Carriage Bolt	51	4	051-8075-00	5/16" fuel line hose
22	2	013-8050-00	1/2-13 Nylon Flange Nut-Orange	52	1	070-2000-00	Clutch Pigtail
23	1	018-2004-00	1/2-13 x 2-1/2 All Thd Stud	53	6	013-5202-00	3/8" Nylock Flange Nut
24	1	057-5910-10	Diesel PTO Engager Holder	54	1	039-5946-98	Pump Idler Assembly Components 3,4,5,6,7,8, only for 61" Deck
25	2	013-5201-00	3/8" Flange Nut	55	1	050-5500-00	Left Pump 16cc - With Fan
26	1	051-8076-00	3/8 hose 4" long	56	1	050-5501-00	Right Pump 16cc - With Fan
27	2	031-5923-00	Pump Arm	57	1	041-5048-00	Pump Belt for 61" Deck
28	2	013-8073-00	1/4" Nylock Nut	58	2	018-0024-00	M6-1.0 X 16MM Hex Bolt
29	2	018-5005-00	1/4" x 1 1/2" Bolt	59	2	019-7040-00	1/4" Flat Washer
30	4	013-6014-00	3/8" Hex Nut	60	2	019-4008-00	1/4" Lock Washer



PARTS SECTION: 1100CC DIESEL BACK PUMP COVER

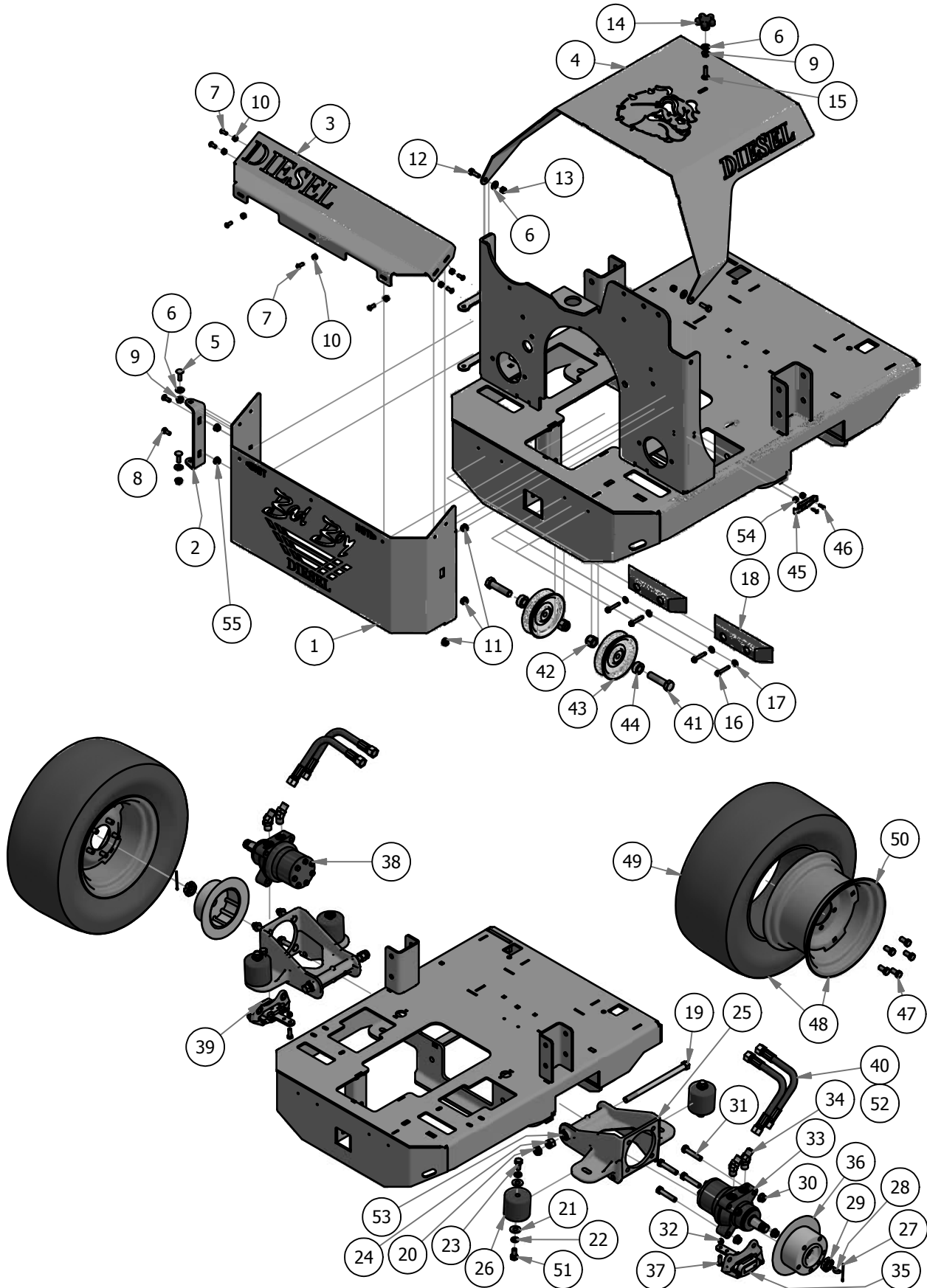



PARTS SECTION: 1100CC DIESEL BACK PUMP COVER

Parts List			
ITEM	QTY	PART NUMBER	DESCRIPTION
1	1	014-5920-00	Diesel Back Pump Cover 2008 Bottom
2	1	039-0070-00	Back Cover Hinge Bracket
3	1	014-5921-00	Diesel Back Pump Cover 2008 Top
4	1	059-8020-10	Diesel Hood 3 Cyl
5	2	018-8065-00	5/16" x 1" Carriage Bolt
6	5	019-6042-00	.360 ID Plastic Washer
7	7	018-8064-00	1/4" x 5/8" BS C/S 18-8 SS
8	2	018-8062-00	5/16-18x3/4 carriage bolt
9	3	013-9002-00	5/16" Flange Nut
10	7	013-8073-00	1/4 Nylock Nut
11	3	014-3010-00	5/8 Round Insert
12	2	018-2007-00	5/16" x 1" Bolt
13	2	013-8047-00	5/16-18 Nylock Insert Locknut
14	1	045-6043-00	5/16" Knob
15	1	018-4703-00	5/16" x 1 1/4" Carriage Bolt
16	4	030-7039-00	1/4" x 1 1/2" Self Tapping Screw
17	4	019-7040-00	1/4" Flat Washer
18	2	029-7038-00	8" Rubber Bumper
19	4	018-2051-00	5/8"x10" Hex Bolt (Grade8)
20	4	013-5301-00	5/8" Nylock (1/2 Jam)
21	16	019-5702-00	1/2" Washer (Grade 8)
22	16	019-5007-00	1/2" Lock Washer
23	8	018-2030-00	1/2" x 1" Hex Bolt
24	4	013-7021-00	5/8 Std NC Nylock Nut
25	2	070-8000-00	60 Suspension kit Wheel Motor
26	8	032-8999-00	Vibration Mount-Blue Dot
27	2	020-7022-00	1/8x2-1/4 cotter pin Zinc
28	2	042-7041-00	Woodruff Key
29	2	013-7050-00	1" Castle Nut for Wheel Motor
30	8	013-5300-00	1/2" Flange Nut
31	8	018-6036-00	1/2" x 2 1/2" Hex Bolt
32	2	013-8047-00	5/16-18 Nylock Insert Locknut
33	1	015-4600-00	18cc Parker Wheel Motor- Right
34	4	024-2050-00	45 Degree Wheel Motor Fitting -6802-10-10
35	1	092-7000-00	XP/AOS Right Brake Caliper
36	2	092-5201-00	Brake Disk
37	2	018-6049-00	3/8" x 1" Hex Bolt
38	1	015-4601-00	18cc Parker Wheel Motor- Left
39	1	092-7001-00	XP/AOS Left Brake Caliper
40	4	051-2080-00	26" Hose Assembly with Adaptors
41	2	018-6059-00	5/8" x 2 1/2" Grade 5 Hex Bolt (Coarse)
42	2	013-7021-00	5/8 Std NC Nylock Nut
43	2	033-7025-00	5 V Idler Pulley - BCVI- 81
44	2	025-7020-00	5/8" x 1" Collar W/One Set Screw
45	1	052-3000-00	Steel Pump Cover Latch
46	2	018-5200-00	10-24 X 5/8 BS Button Head Bolt
47	10	018-7033-00	1/2" x 1" Hex Bolt
48	2	022-7031-00	26 x 12.00 - 12 Tire and Orange Wheel Assembly
49	2	022-7032-00	26 x 12.00 - 12 Tire
50	2	022-7034-00	12 x 10.5 Wheel AOS Rear
51	4	018-2080-00	1/2-13 1-1/4 Hex bolt
52	4	051-6085-00	26" Hose Only
53	4	032-6033-00	Brass Bushing
54	2	013-5019-00	10-24 Nylock Locknut
55	2	013-8049-00	5/16" Nylon Flange Nut



PARTS SECTION: RADIATOR ASSEMBLY

Parts List				Parts List			
ITEM	QTY	PART NUMBER	DESCRIPTION	ITEM	QTY	PART NUMBER	DESCRIPTION
1	1	061-5000-00	Radiator- Diesel	13	2	019-5029-00	3/8" Flat Washer
2	1	094-5088-00	Radiator Screen-Diesel	14	2	013-6014-00	3/8" Hex Nut
3	1	072-8090-00	Diesel Clamp 1 3/4" Vinyl	15	2	084-4015-00	Rubber Trim
4	1	051-3000-00	Top Radiator Hose for Diesel	16	1	015-0111-00	overflow Reservoir- 28/35Hp Diesel
5	1	051-3001-00	Bottom Radiator Hose for Diesel	17	1	051-8069-00	5/16 Clear Hose
6	4	072-2003-00	1 1/8" Hose Clamp	18	1	066-8075-00	Reservoir Tank Cap-Overflow
7	1	013-8049-00	5/16" Nylon Flange Nut	19	1	019-7040-00	1/4" Flat Washer
8	1	018-2007-00	5/16" x 1" Hex Bolt	20	1	019-4008-00	1/4" Lock Washer
9	1	039-1015-00	Diesel Radiator Hose Clamp Bracket	21	1	013-8039-00	1/4" Hex Nut
10	1	015-0104-00	Radiator cap	22	1	018-8052-00	1/4" x 3/4" Hex Bolt
11	4	019-5050-00	3/8 x 2-1/4 OD Fibre Washer	23	1	030-7040-00	1/4 x 1 Hex Head tek screw
12	2	019-5037-00	3/8" Lock Washer	24	1	201-8010-00	Bolt On Radiator Support

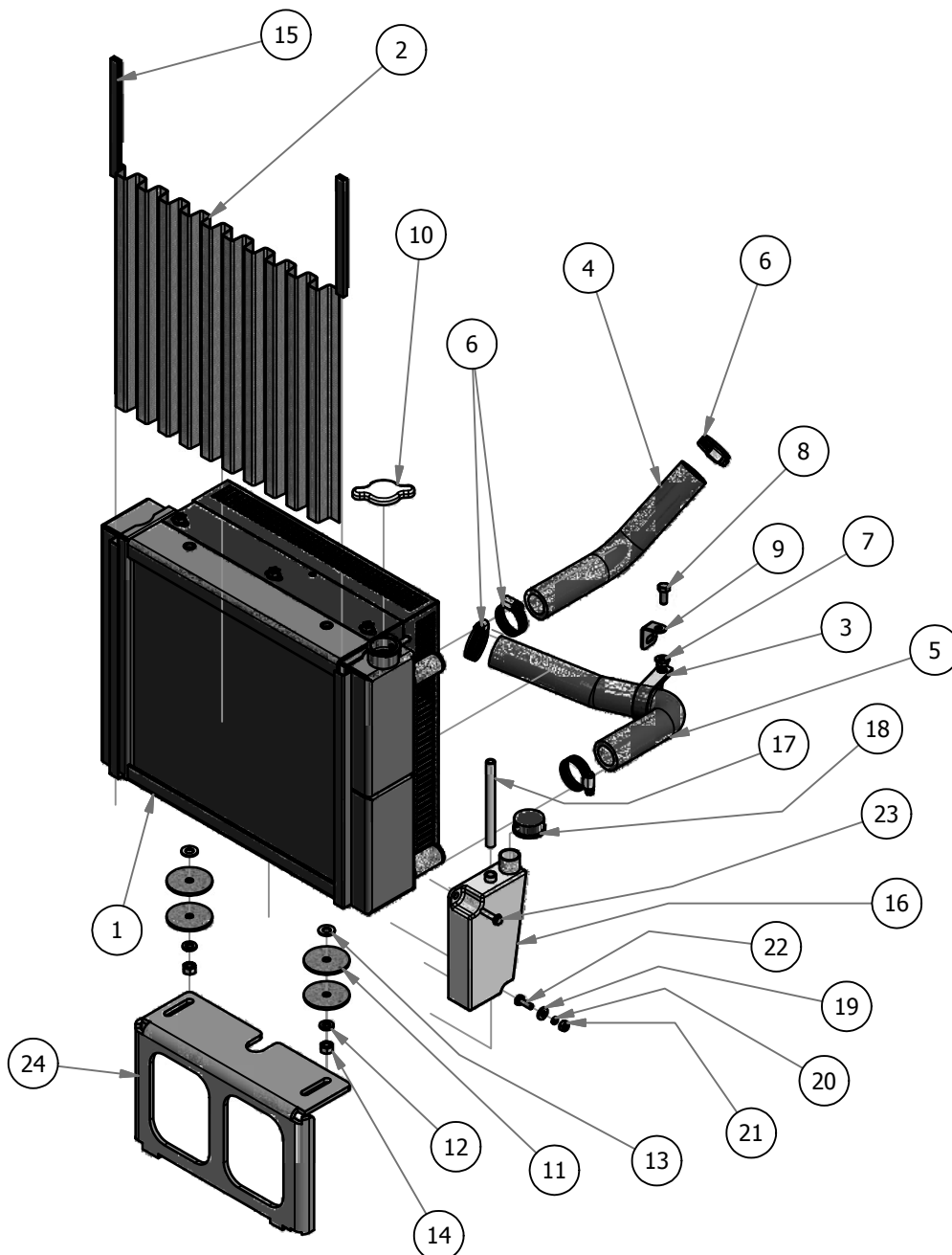



PARTS SECTION: DIESEL AIR FILTER ASSEMBLY

Diesel Air Filter Assembly				Diesel Air Filter Assembly			
ITEM	QTY	PART NUMBER	DESCRIPTION	ITEM	QTY	PART NUMBER	DESCRIPTION
1	1	088-1018-00	Canister for All Diesel Models	8	2	019-8051-00	5/16" Lock Washer
2	1	088-1017-00	Enginaire Air canister cap	9	2	018-5344-00	5/16" x 2 1/2" Bolt
3	1	088-1019-00	Mounting Bracket For Diesel Air Filter	10	2	025-8000-00	.378 x .625x 1.750 Spacer Zinc
4	1	063-2050-00	Diesel Air Filter- Outer	11	1	051-3002-00	Air Intake Hose-Diesel Air Filter Canister
5	1	063-2060-00	Diesel Air Filter- Inner	12	2	072-2002-00	2-1/2" Hose Clamp
6	1	088-1020-00	Debris Plug-Enginaire Filter	13	1	088-1010-50	Enginaire Canister VLR-Complete Assembly
7	2	013-8043-00	5/16" Nut				

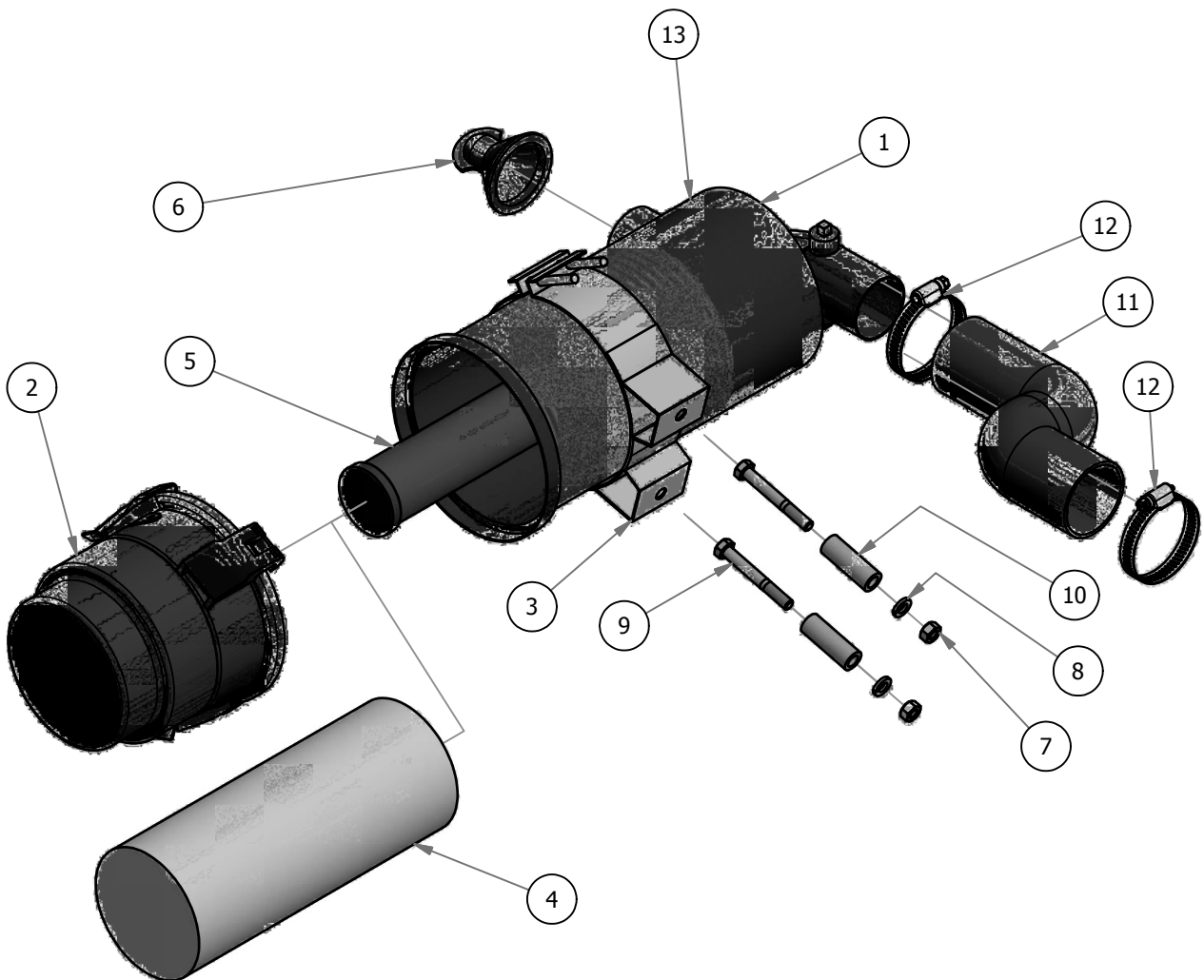



PARTS SECTION: 1100CC DIESEL ENGINE

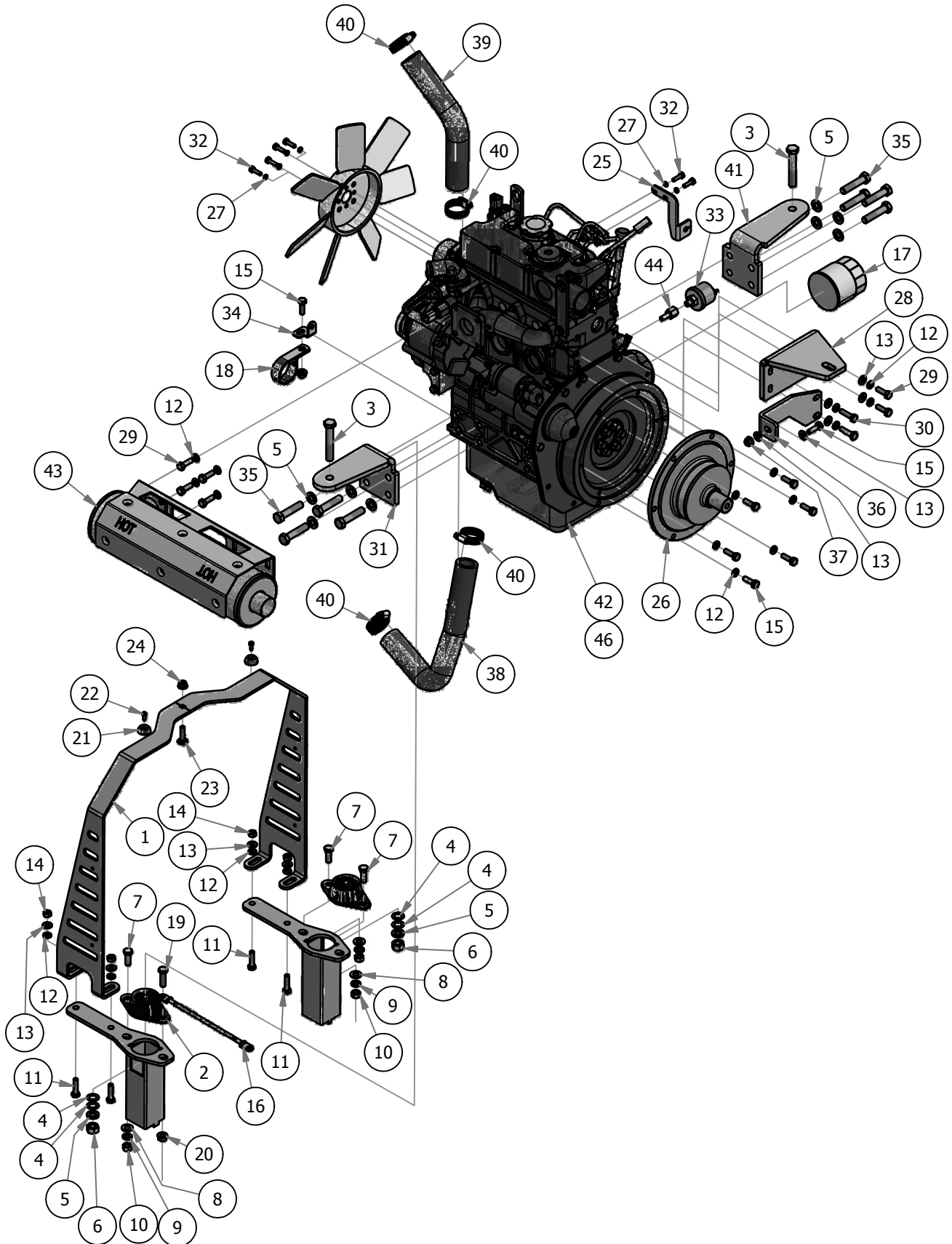



PARTS SECTION: 1100CC DIESEL ENGINE

Parts List			
ITEM	QTY	PART NUMBER	DESCRIPTION
1	1	201-8001-00	Hood Holder Diesel
2	2	032-4050-00	Rubber Isolator
3	2	018-7016-00	1/2" x 3" Hex Bolt
4	4	019-5010-00	1/2" Brass Washer
5	10	019-5007-00	1/2" Lock Washer
6	2	013-7018-00	1/2" Hex Nut
7	3	018-6049-00	3/8" x 1" Hex Bolt
8	3	019-5029-00	3/8" Flat Washer
9	3	019-5037-00	3/8" Lock Washer
10	3	013-6014-00	3/8" Hex Nut
11	4	018-5025-00	5/16" x 1 1/4" Hex Bolt
12	18	019-8051-00	5/16" Lock Washer
13	10	019-8044-00	5/16" Flat Washer
14	4	013-8043-00	5/16" Nut
15	8	018-2007-00	5/16" x 1" Bolt
16	1	064-4001-00	Black Battery Cable - Diesel
17	1	063-2010-00	CAT Oil Filter
18	1	072-8090-00	Diesel Clamp 1 3/4" Vinyl
19	1	018-6012-00	3/8" x 1 1/2" Hex Bolt
20	3	013-5201-00	3/8" Flange Nut
21	2	029-4010-00	Button Bumper
22	2	030-3050-00	#10 x 1/2" Self Tapping Screw
23	1	018-4703-00	5/16" x 1 1/4" Carriage Bolt
24	1	013-8049-00	5/16" Nylon Flange Nut
25	1	039-1010-00	Diesel Throttle Bracket (4 Tier)
26	1	017-3000-00	Stub Shaft
27	6	019-4008-00	1/4" Lock Washer
28	1	201-8005-00	Air Cleaner Support Diesel
29	6	018-2001-00	M8 x 1.25 x 25mm Hex Head Bolt
30	2	018-5320-00	M8 x 1.25 x 30mm Hex Head Bolt
31	1	201-8008-00	Diesel Motor Side Support
32	6	018-2000-00	6mm x 20mm Bolt
33	1	086-7004-00	oil pressure guage sender
34	1	039-1015-00	Diesel Radiator Hose Clamp Bracket
35	8	018-6022-00	12mm Bolt- Diesel
36	1	203-8000-00	Muffler Brace Diesel
37	2	013-9002-00	5/16" Flange Nut
38	1	051-3001-00	Bottom Radiator Hose for Diesel
39	1	051-3000-00	Top Radiator Hose for Diesel
40	4	072-2003-00	1 1/8" Hose Clamp
41	1	201-8009-00	Diesel Side Motor Mount (Left)
42	1	015-0001-00	1100cc Diesel
43	1	015-0010-00	Diesel Muffler
44	1	024-0070-00	8mm x 1/8in mpt Oil Pressure Adaptor
45	1	063-2012-00	Internal Fuel Filter (Not Pictured)
46	1	015-0096-00	1100cc Perkins Engine



PARTS SECTION: OUTLAW DIESEL 61" DECK

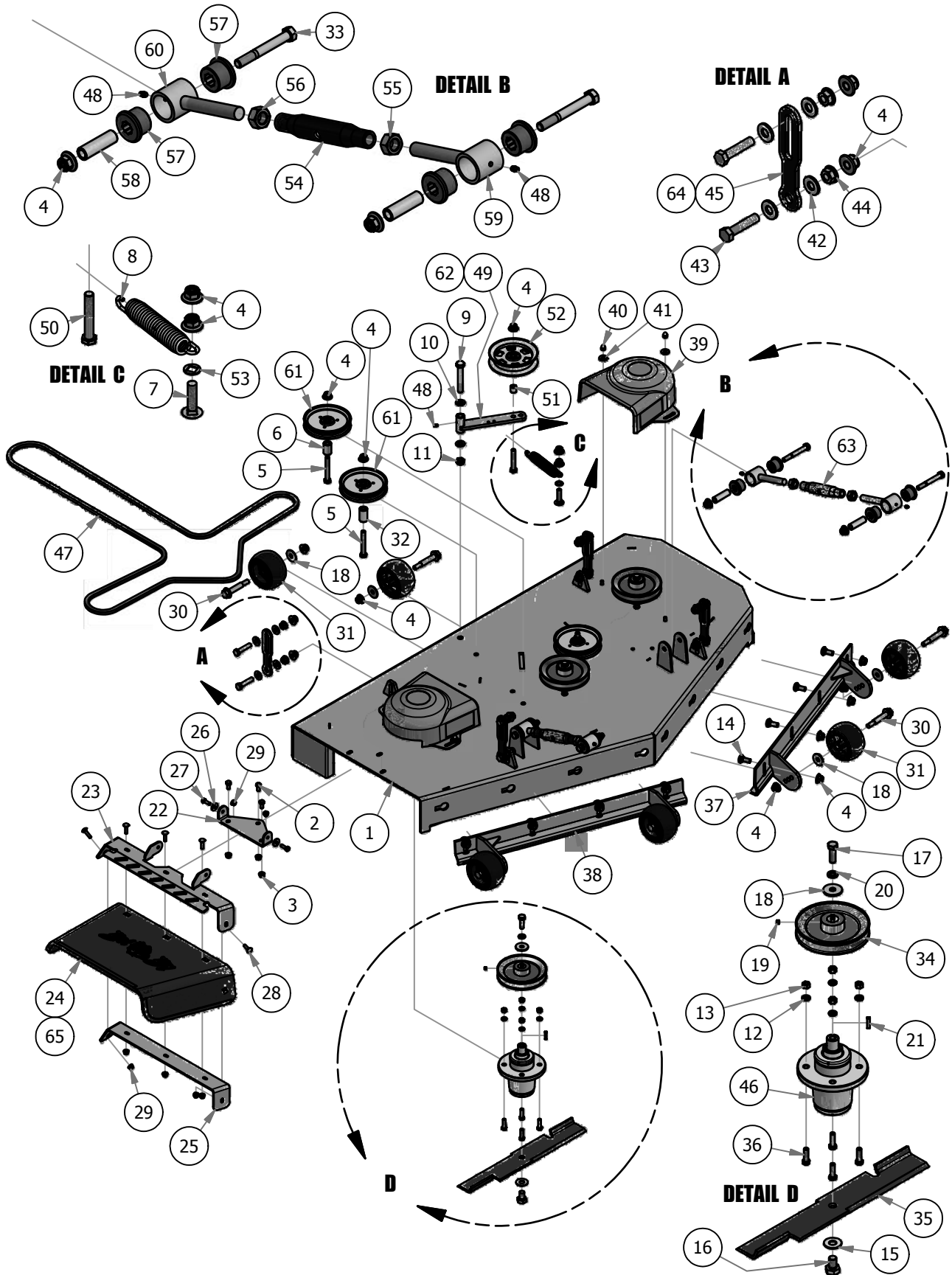



PARTS SECTION: OUTLAW DIESEL 61" DECK

Parts List				Parts List			
ITEM	QTY	PART NUMBER	DESCRIPTION	ITEM	QTY	PART NUMBER	DESCRIPTION
1	1	060-6150-00	2015 61" Deck	34	3	033-6004-00	6 1/4" Drive Pulley
2	3	018-5250-00	3/8" x 3/4" Hex Bolt	35	3	038-6080-00	61 inch Fusion Blade
3	3	013-5201-00	3/8" Flange Nut	36	12	018-5040-00	3/8" x 1 1/4" Hex Bolt
4	32	013-8050-00	1/2-13 Nylon Flange Nut	37	1	060-6220-00	61 Deck Adjustable Front (Left)
5	3	018-2018-00	1/2 x 3 1/2 Flange Bolt Grade 8	38	1	060-6210-00	61 Deck Adjustable Front (Right)
6	2	025-5338-00	Idler Pulley Standoff	39	2	014-5000-00	Pulley Cover
7	1	018-1050-00	1/2 x 2" Carriage Bolt	40	4	013-0004-00	Acorn nut-pulley Cover
8	1	034-2020-00	Deck Idler Spring	41	4	019-6050-00	.360 ID Plastic Washer-Black
9	1	018-5311-00	5/8" x 4" Hex Bolt	42	16	019-8054-00	.505 Nylon Spacer
10	2	019-6017-00	.630 ID Plastic Washer	43	8	018-6037-00	1/2-13X 2-1/4 GR Hex Bolts
11	1	013-5301-00	5/8-11 Nylon Insert Jam Half Nut	44	8	013-5300-00	1/2" Flange Nut
12	12	019-5037-00	3/8 Lockwasher Zinc	45	4	039-2125-00	Deck_Hanging_Tab
13	12	013-6014-00	3/8-16 Hex Nuts Zinc	46	3	037-4000-00	OUTLAW SPINDLE ASSEMBLY
14	8	018-3003-00	1/2" x 1 1/4 Carriage Bolt	47	1	041-0226-00	B226 Belt for 1100cc Diesel
15	3	019-5038-00	5/8" Flat Washer	48	5	024-6034-00	1/4" Press in Grease Fitting
16	3	018-6020-00	5/8" x 1 1/2" Grade 8 Hex Bolt (Fine)	49	1	039-6945-00	Deck Idler
17	3	018-6019-00	1/2"-20 x 1 1/2 - Grade 5 Fine Thread Bolt	50	1	018-7016-00	1/2-13 x GR 5 Hex Bolt Zinc
18	9	019-6020-00	1/2" Belleville Washer	51	1	025-5203-00	Spacer 3/4 OD x 1/2 ID x 3/4 Length
19	3	030-0050-00	5/16 Set Screw	52	1	033-8050-00	5" Idler Pulley
20	3	019-5007-00	1/2" Lock Washer	53	1	019-0007-00	.517 Square Hole Round Washer
21	3	042-6030-00	1/4" x 1" Key	54	2	048-7020-00	2015 Outlaw Toplink Body
22	1	206-6017-00	Discharge Chute Hanger (deck mounted)	55	2	013-0008-00	3/4-10 Left-Handed Hex Nuts Zinc
23	1	039-4864-00	60" Discharge Chute Upper Hanger	56	2	013-0007-00	3/4-10 Hex Nuts Zinc
24	1	210-6005-00	Rubber Discharge Chute	57	8	032-2000-00	Bushing
25	1	039-4863-00	60" Discharge Lower Bracket	58	4	032-2001-00	Sleeve
26	2	019-6042-00	.360 ID Plastic Washer	59	2	048-7022-00	Turn Left-Handed
27	2	018-2007-00	5/16" x 1" Bolt	60	2	048-7021-00	Right-Handed End
28	5	018-4703-00	5/16" x 1 1/4" Carriage Bolt	61	3	033-7201-25	5-3/4 Idler Pulley-Capitol Stampings
29	7	013-8049-00	5/16" Nylock Flange Nut Zinc	62	1	039-6945-01	Deck Idler Assembly - Includes parts: 4, 49, 48, 50, 51, 52,
30	6	018-0010-00	Deck Wheel Bolt	63	2	048-7000-00	Turnbuckle Assembly
31	6	022-1000-00	Anti-Scalp Roller	64	1	039-2125-17	Outlaw Deck Hanger Assembly - Includes Parts:4,42,43,44,45
32	1	025-5339-00	1 3/4" Pulley Spacer	65	1	210-6005-98	Chute Assembly - Includes Parts:23,24,25,28,29
33	4	018-5019-00	1/2" x 4" Bolt (Grade 8)				



PARTS SECTION: 037-4000-00 DOUBLE BEARING SPINDLE

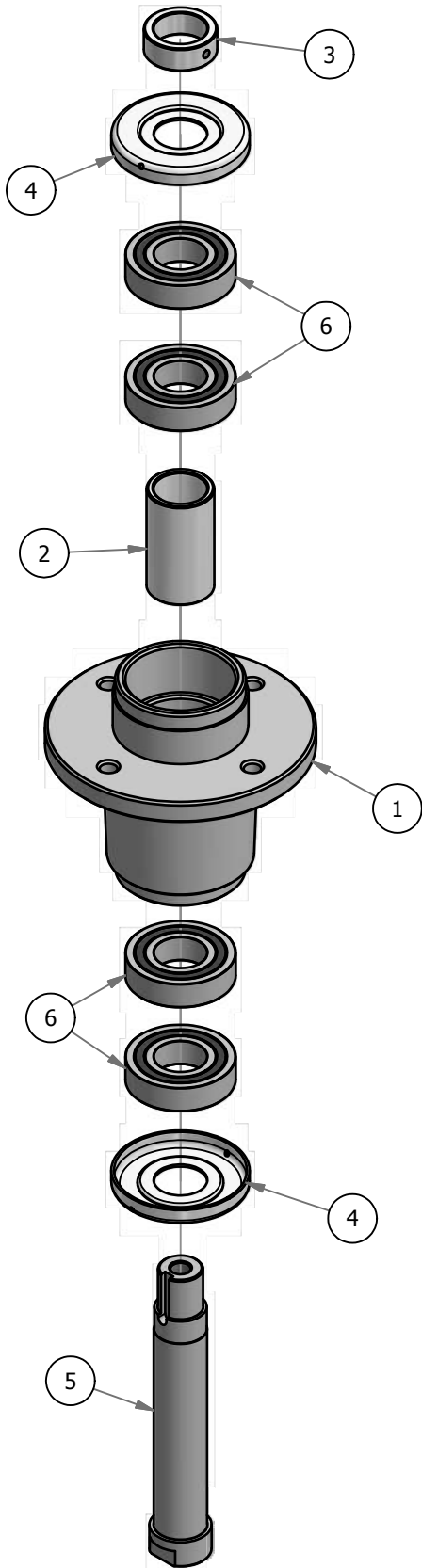

Parts List			
ITEM	QTY	PART NUMBER	DESCRIPTION
1	1	037-4000-01	4000 Series Spindle Housing
2	1	037-4002-00	4000 Series Spindle Spacer
3	1	037-9050-00	Locking Collar w/ 1/4"-20 Set Screw
4	2	037-8002-00	Spindle Dust Cap
5	1	037-6026-00	Spindle Shaft
6	4	037-6029-00	Bearing - Peer 6206



PARTS SECTION: DECALS



091-0902-00
BAD BOY FLOORBOARD LOGO DECAL



091-0919-18
ARMORTEK5 DECAL



091-2001-18
OVAL LOGO DECAL



091-1101-18
BRAKE DECAL



091-1114-00
STEERING SPEED CONTROL DECAL



091-0917-18
61" DECK DECAL



091-0361-18
1100cc REAR COVER DECAL



091-3060-00
SWING AWAY PATENT DECAL



091-1104-18
THROTTLE DECAL

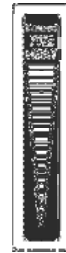

091-2063-18
PREHEAT DECAL

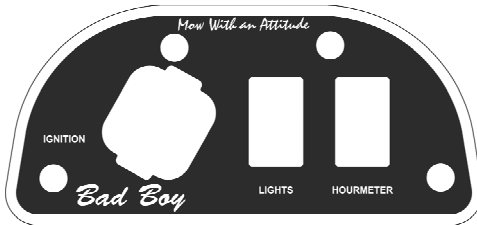

091-2061-18
LEFT CONTROL PANEL DECAL

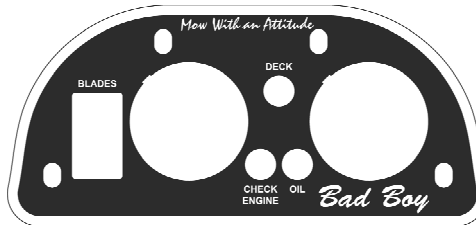

091-3061-18
RIGHT CONTROL PANEL DECAL

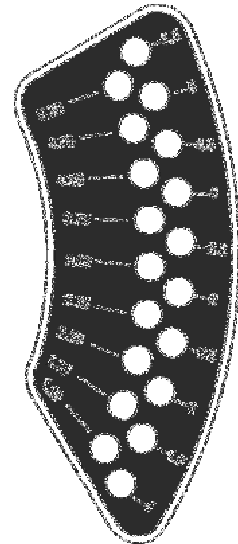

091-1105-18
DECK HEIGHT DECAL

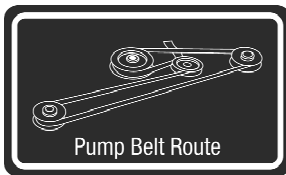

091-3017-00
PUMP BELT ROUTE DECAL

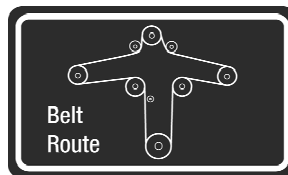

091-3309-00
DECK BELT ROUTE DECAL



091-8000-00
EZ RIDE PATENT DECAL



091-8001-00
DECK IMPACT PATENT DECAL

LOW SULFUR FUEL OR ULTRA LOW SULFUR FUEL ONLY 300100300

091-2050-00
LOW SULFUR DECAL

<p>! DANGER</p> <p>NEVER MOW SIDE HILL OVER 5°</p> <p>NEVER MOW UP HILL OVER 10°</p> <p>NEVER MOW SLOPE OVER 15°</p> <p>NEVER MOW NEAR PEOPLE</p> <p>NEVER USE WHEN UNDER THE INFLUENCE OF DRUGS OR ALCOHOL - NEVER CARRY PASSENGERS</p> <p>SET PARKING BRAKE & REMOVE KEY IF LEAVING MACHINE - AVOID SLIPPERY OR STEEP AREAS</p> <p>AVOID BLADE UNLESS BLADE & ENGINE ARE STOPPED - USE SAFELY. MACHINE IS NOT A TOY</p> <p>KNOW LOCATION AND FUNCTION OF CONTROLS - REMOVE POTENTIAL THROWN OBJECTS</p> <p>KEEP SAFETY DEVICES IN PLACE AND WORKING - LOOK BEHIND MACHINE BEFORE BACKING</p> <p>• READ OWNER'S MANUAL •</p>	<p>! CAUTION</p> <p>Shut off engine before refueling. Never fill fuel tank indoors or when engine is hot.</p> <p>Wipe up all spilled fuel before starting engine.</p> <p>Do not smoke while refueling.</p> <p>Do not operate this machine unless you are trained.</p>	<p>! CAUTION</p>

091-3300-00
DANGER/CAUTION DECAL

CAUTION

WHEN ADDING OIL FOR HYDROSTATICS, USE MULTIVISCOSITY 20W-50. DO NOT ADD AUTOMATIC TRANSMISSION FLUID OR HYDRAULIC FLUID! THIS WILL VOID THE WARRANTY

091-3015-00
CAUTION DECAL

! DANGER

KEEP HANDS & FEET AWAY. DO NOT OPERATE MOWER UNLESS GUARD OR GRASS CATCHER IS ATTACHED.

091-3012-00
DANGER DECAL



**2018 LIMITED WARRANTY
FOR
BAD BOY COMMERCIAL MOWER
(STAND ON, WALK-BEHIND, DIESEL, OUTLAW, OUTLAW EXTREME, AND OUTLAW XP)**

1. WHAT THIS WARRANTY COVERS, AND FOR HOW LONG:

Bad Boy, Inc. will, at its option, repair or replace, without charge, any part covered by the warranty which is found to be defective in material and/or workmanship for two (2) years * after the date of sale to the original retail purchaser unless the product is used for rental purposes, in which case this warranty is limited to ninety (90) days.

The leading edge of the deck shell will be warranted for the entire lifetime of the machine to the original purchaser against defects in materials and workmanship. Labor required to repair or replace the leading edge of the deck shell will be covered by Bad Boy Inc. for two years and at the unit owner's expense during the balance of the lifetime of the machine.

Belts are warranted for a period of ninety (90) days against materials or workmanship defects.

Seats are warranted for a period of (6) months against material or workmanship defects.

At Bad Boy, Inc.'s request, customer will make the defective part available for inspection by Bad Boy, Inc. and/or return the defective part to Bad Boy, Inc., transportation charges prepaid.

2. WHAT THIS WARRANTY DOES NOT COVER:

A. This warranty does not cover defects caused by depreciation or damage caused by normal wear, accidents, improper maintenance, improper use or abuse of the product, alterations, or failure to follow the instruction contained in the Owner's Manual for operation and maintenance.

B. The customer shall pay any charges for making service calls and/or for transporting the mower to and from the place where the inspection and/or warranty work is performed.

Bad Boy Inc will not be responsible for the pickup and delivery of a machine for warranty purposes.

C. Engines are warranted separately by their respective manufacturer. The available warranties covering this item are furnished with each mower. Bad Boy, Inc does not assume any warranty obligation, liability or modification for this item, which is covered exclusively by the stated warranty of the respective manufacturers.

D. Tires, blades, deck anti-scalping wheels, and dust covers are considered to be consumable wear items and are therefore not warranted.

E. Batteries are warranted for six months (free replacement) from the retail purchase date against materials or workmanship defects. The battery warranty must be obtained through the battery manufacturer.

F. Normal maintenance services such as oil change, cleaning, lubrication, adjustment.

G. Replacement of services, items, such as oil, lubricants, spark plugs, belts, rubber hoses or other items subject to normal service replacement.

3. HOW TO OBTAIN SERVICE UNDER THIS WARRANTY:

A. Warranty service can be arranged by contacting the dealer where you purchased the mower. Proof of the date of purchase may be required to verify warranty coverage. Warranty repairs must be completed by an authorized Bad Boy center.

B. Warranty claims will not be reviewed or paid unless the warranty registration is received by Bad Boy, Inc. within 30 days of the retail purchase date.

C. Warranty claims requiring parts returned will be settled upon return of parts to Bad Boy for inspection.

D. All warranty issues must be handled through an authorized service center or dealership.

4. WARRANTY LIMITATION:

A. **THERE IS NO OTHER EXPRESS WARRANTY. ANY WARRANTY THAT MAY BE IMPLIED FROM THIS PURCHASE INCLUDING MERCHANTABILITY AND FITNESS FOR A PARTICULAR PURPOSE IS HEREBY LIMITED TO THE DURATION OF THIS WARRANTY AND TO THE EXTENT PERMITTED BY LAW ANY AND ALL IMPLIED WARRANTIES ARE EXCLUDED.** Some states do not allow limitations on how long an implied warranty lasts, so the above limitations may not apply to you.

B. **BAD BOY, INC. WILL NOT BE LIABLE FOR ANY INCIDENTAL, CONSEQUENTIAL, OR SPECIAL DAMAGES AND/OR EXPENSES IN CONNECTION WITH THE PURCHASE OR USE OF THE MOWER.** Some states do not allow the exclusion or limitation of incidental or consequential damages, so the above limitation(s) or exclusion(s) may not apply to you.

C. Only the warranty expressed in this limited warranty shall apply and no dealer, distributor, or individual is authorized to amend, modify, or extend this warranty in any way. Accordingly, additional statements such as dealer advertising or presentations, whether oral or written, do not constitute warranties by Bad boy, Inc., and should not be relied on.

D. This warranty extends only to turf equipment operated under normal conditions and properly serviced and maintained. The warranty expressly does not cover (i) any defects, damage or deterioration due to normal use, wear and tear, or exposure; (ii) normal maintenance services such as oil change, cleaning, lubrication, adjustment; (iii) replacement of services, items, such as oil, lubricants, spark plugs, belts, rubber hoses or other items subject to normal service replacement; (iv) damage or defects arising out of or relating to misuse, neglect, alteration, negligence or accident; (v) repair or replacement arising from operation of or use of the turf equipment which is not in accordance with operating instructions as specified in the operator's manual or other operational instructions provided by Bad Boy Inc.; (vi) repair or replacement arising as a result of any operation from turf equipment that has been altered or modified so as to, indetermination of Bad Boy, Inc., adversely affect the operation, performance or durability of the equipment or that has altered, modified or affected the turf equipment so as to change the intended use of the product; (vii) repair or replacement necessitated by use of parts, accessories or supplies, including gasoline, oil or lubricants, incompatible with the turf equipment or other than as recommended in the operator's manual or other operational instructions provided by Bad Boy, Inc.; (viii) repairs or replacements resulting from parts or accessories which have adversely affected the operation, performance or durability of the turf equipment; or (ix) damage or defects due to or arising out of repair of turf equipment by person or persons other than an authorized Bad Boy, Inc., service dealer or the installation of parts other than genuine Bad Boy, Inc., recommended parts.

As a condition to this warranty, customer shall have read the operator's manual and ensured the mower has been registered within 30 days of purchase.

E. This warranty gives you specific legal rights, and you may also have other rights, which vary from state to state.



BAD BOY, INC.
102 INDUSTRIAL DRIVE
BATESVILLE, AR 72501
WWW.BADBOYMOWERS.COM

Technical Support: techsupport@badboymowers.com
Warranty:..... warranty@badboymowers.com
Parts: partsdept@badboymowers.com

WARRANTY REGISTRATION

**Ensure selling dealership has registered mower within
30 days of purchase to validate warranty.**

Please record your serial number, date of purchase and dealership information
for your records.

Serial # _____

Date of Purchase _____

Dealer Information _____



For additional information, please see us at
www.badboymowers.com

Bad Boy, Inc.
102 Industrial Drive
Batesville, Arkansas 72501